



**PEMERINTAH KOTA SEMARANG  
DINAS PEKERJAAN UMUM**

JL. MADUKORO RAYA NO. 7, TELP. (024) 76433969, FAX. (024) 76433969 KOTA SEMARANG

---

**FORM INVENTARISASI JEMBATAN  
Ruas Jalan  
BANGKONG**

**NO JEMBATAN : KT.33.074.12.0003.002**  
**NAMA JEMBATAN : BANGKONG 2**  
**TAHUN ANGGARAN : 2024**



**PEMERINTAH KOTA SEMARANG**  
**DINAS PEKERJAAN UMUM**

JL. MADUKORO RAYA NO. 7, TELP. (024) 76433969, FAX. (024) 76433969 KOTA SEMARANG

SISTEM  
MANAJEMEN  
JEMBATAN



## LAPORAN PEMERIKSAAN INVENTARISASI JEMBATAN

No. Jembatan Ruas Jalan Kabupaten dan Kota

KT	3	3	0	7	4	1	2	0	0	0	3	0	0	2
----	---	---	---	---	---	---	---	---	---	---	---	---	---	---

Nama Jembatan	<b>BANGKONG 2</b>				Propinsi / Kabupaten / Kota Semarang	
Lokasi Jembatan	Koordinat Awal : -7,0477650 LS	110,4043090 BT	Dari (Kota Asal/Km.No1) : SMG			
	Koordinat Akhir : -7,0477650 LS	110,4043090 BT	Km. (Jarak dari kota asal) : 0+270			
Tanggal Pemeriksaan 5/9/2024	Nama Pemeriksa / NIP GENDUT SUMANTO				Tahun Pembangunan	
Nilai Lalu - Lintas :	0.642997	LHR : 2709,1	Tahun : 2019			

### INFORMASI PEMBANGUNAN JEMBATAN

1 Tanggal / Bulan / Tahun pembangunan jembatan / pengoperasian pertama kali	:	
2 Tanggal / Bulan / Tahun pelebaran/rehabilitasi/perkuatan jembatan / pengoperasian pertama kali	:	
3 Tanggal / Bulan / Tahun serah terima aset	:	
4 Penanggung jawab pembangunan (Satker/PPK)	:	
5 Penanggung jawab pelebaran/rehabilitasi/perkuatan jembatan (Satker/PPK)	:	
6 Biaya perencanaan	:	
7 Biaya pembangunan	:	
8 Biaya pelebaran/rehabilitasi/perkuatan jembatan	:	
9 Biaya pengujian	:	
10 Nilai aset serah terima	:	
11 Nama konsultan perencana pembangunan	:	
12 Nama <i>Independent Proof Checker</i> (IPC)	:	
13 Nama konsultan perencana pelebaran/rehabilitasi/perkuatan jembatan	:	
14 Nama kontraktor pelaksana pembangunan	:	
15 Nama kontraktor pelaksana pelebaran/rehabilitasi/perkuatan jembatan	:	
16 Nama subkontraktor spesialis	:	
17 Nama konsultan pengawas pembangunan	:	
18 Nama konsultan pengawas pelebaran/rehabilitasi/perkuatan jembatan	:	
19 Nama konsultan pengujian	:	
	Tersedia / Tidak	File
20 Laporan pembangunan/pelebaran/rehabilitasi/perkuatan jembatan	:	
21 <i>As-built-drawing</i> atau denah jembatan	:	

Hanya untuk keperluan kantor

Tanggal memasukkan Data Pemeriksaan Inventarisasi 5/31/2024	Oleh : WAHYU DWIS
----------------------------------------------------------------	----------------------



**PEMERINTAH KOTA SEMARANG**  
**DINAS PEKERJAAN UMUM**

JL. MADUKORO RAYA NO. 7, TELP. (024) 76433969, FAX. (024) 76433969 KOTA SEMARANG

### INFORMASI KAPASITAS MUATAN

1 Batasan muatan sumbu terberat MST	:	4	ton
2 Beban maksimum yang pernah di atas jembatan	:	4	ton
3 Jenis kendaraan berat yang umum lewat di atas jembatan	:	MOBIL	
4 Tindakan darurat yang sedang/pernah dilakukan di atas jembatan	:	D	
a. Pembatasan beban			
b. Penyokongan/Sangga			
c. Penutupan parsial/Sebagian			
d. Penutupan penuh			
e. Jalan Memutar/ <i>detour</i>			
f. Jembatan Sementara			
5 Apakah tersedia jalan memutar/ <i>detour</i> jika jembatan ditutup		Ya	tidak
6 Panjang jarak tambahan yang harus ditempuh dengan jalan memutar	-		m

### INFORMASI KAPASITAS LALU LINTAS

1 Lalu - lintas harian rata-rata tahunan (LHR) AADT	:	2709,144	
2 Nilai Lalu - Lintas (Perbandingan lebar jalur lalu-lintas yang tersedia di atas jembatan dengan lebar perkerasan sebelum masuk ke dalam jembatan			
Longgar kendaraan bebas melintas di atas jembatan		0	
Cukup lebar kendaraan melaju perlahan di atas jembatan		3	
Sempit kendaraan harus antri atau berhenti		5	
3 Lebar kendaraan maksimum ( <i>ODOL/Over-dimension overload vehicle</i> )	:	2	m

### INFORMASI BATASAN PERLINTASAN DAN LINGKUNGAN

1 Tinggi muka air banjir terhadap bagian atas lantai jembatan	:	1,5	m
2 Tinggi muka air banjir terhadap elevasi perletakan jembatan	:	-	m
3 Tinggi muka air banjir terhadap elevasi terbawah bangunan atas jembatan	:	1,2	m
4 Kedalaman gerusan di sekitar pilar	:	-	m
5 Kedalaman gerusan di sekitar kepala jembatan	:	-	m
6 Kedalaman gerusan di sekitar tanah timbunan atau bangunan pengaman lainnya	:	-	m
7 Tinggi bebas perlintasan <i>overpass</i> jalan	:	-	m
8 Tinggi bebas perlintasan kereta api	:	-	m
9 Tinggi bagian tertinggi dari kapal laut dan/atau angkutannya terhadap elevasi terbawah bangunan atas jembatan	:	-	m
10 Lebar alur pelayaran untuk dibandingkan dengan kapal laut	:	-	m
11 Tinggi pylon dengan batasan lintasan pesawat udara dekat bandara	:	-	m









**PEMERINTAH KOTA SEMARANG**  
**DINAS PEKERJAAN UMUM**

JL. MADUKORO RAYA NO. 7, TELP. (024) 76433969, FAX. (024) 76433969 KOTA SEMARANG

NO. JEMBATAN :

KT	3	3	0	7	4	1	2	0	0	0	3	0	0	2	0
----	---	---	---	---	---	---	---	---	---	---	---	---	---	---	---

NAMA JEMBATAN :

BANGKONG 2

**POTONGAN MEMANJANG**

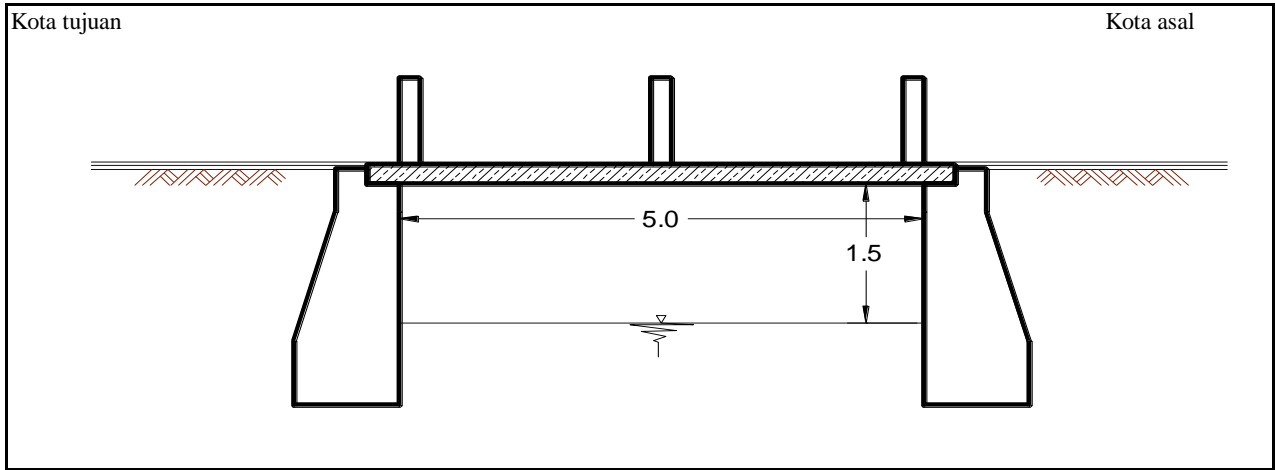

**TAMPAK ATAS**

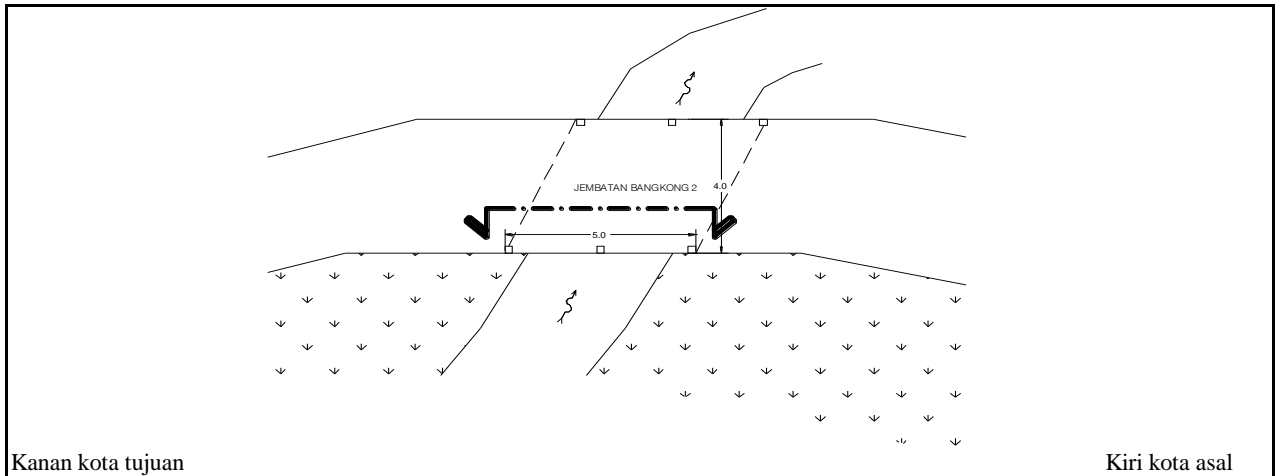

**SITUASI**

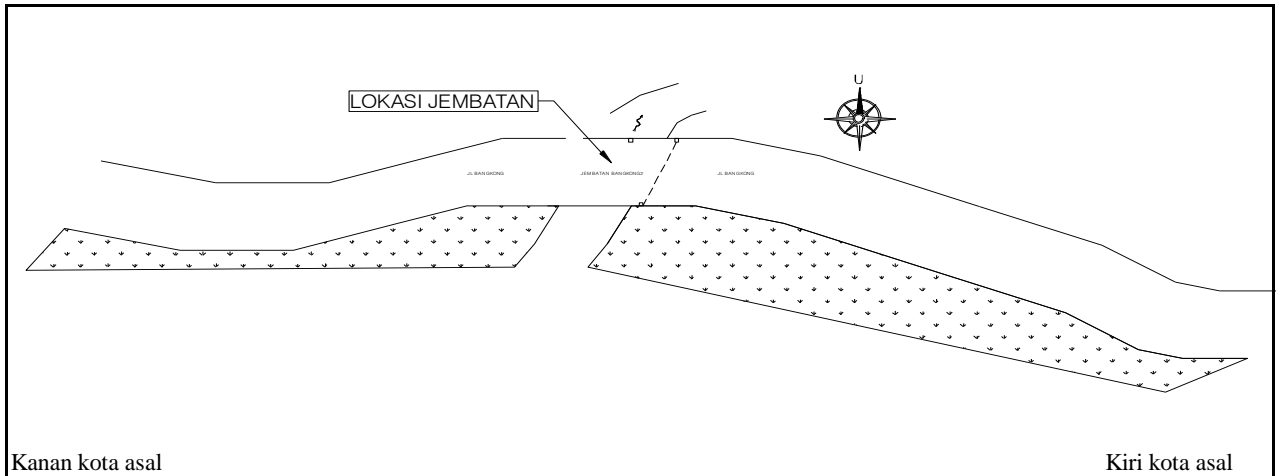



**PEMERINTAH KOTA SEMARANG**  
**DINAS PEKERJAAN UMUM**

JL. MADUKORO RAYA NO. 7, TELP. (024) 76433969, FAX. (024) 76433969 KOTA SEMARANG



**TAMPAK MEMANJANG**



**TAMPAK MEMANJANG**



**TAMPAK MELINTANG**



**TAMPAK MELINTANG**

<b>NOMOR JEMBATAN</b>	<b>NAMA JEMBATAN</b>	<b>LOKASI (Km)</b>	<b>PANJANG (M)</b>
KT.33.074.12.0003.002	BANGKONG 2	0+270	5,00





**PEMERINTAH KOTA SEMARANG  
DINAS PEKERJAAN UMUM**

JL. MADUKORO RAYA NO. 7, TELP. (024) 76433969, FAX. (024) 76433969 KOTA SEMARANG



**KONDISI ALIRAN SUNGAI**



**KEPALA JEMBATAN BERLUMUT DAN  
MENGALAMI PENUAAN**



**KONDISI PIPA UTILITAS AIR MINUM**



**SANDARAN JEMBATAN TERLALU RENDAH**

<b>NOMOR JEMBATAN</b>	<b>NAMA JEMBATAN</b>	<b>LOKASI (Km)</b>	<b>PANJANG (M)</b>
KT.33.074.12.0003.002	BANGKONG 2	0+270	5,00



**PEMERINTAH KOTA SEMARANG  
DINAS PEKERJAAN UMUM**

JL. MADUKORO RAYA NO. 7, TELP. (024) 76433969, FAX. (024) 76433969 KOTA SEMARANG

---

**FORM DETAIL JEMBATAN  
Ruas Jalan  
BANGKONG**

**NO JEMBATAN : KT.33.074.12.0003.002**  
**NAMA JEMBATAN : BANGKONG 2**  
**TAHUN ANGGARAN : 2024**



**PEMERINTAH KOTA SEMARANG  
DINAS PEKERJAAN UMUM**

JL. MADUKORO RAYA NO. 7, TELP. (024) 76433969, FAX. (024) 76433969 KOTA SEMARANG

SISTEM  
MANAJEMEN  
JEMBATAN



## LAPORAN PEMERIKSAAN DETAIL JEMBATAN

No. Jembatan Ruas Jalan Kabupaten dan Kota

KT	3	3	0	7	4	1	2	0	0	0	3	0	0	2	0
----	---	---	---	---	---	---	---	---	---	---	---	---	---	---	---

Nama Jembatan	BANGKONG 2				Propinsi / Kabupaten / Kota Semarang	
Lokasi Jembatan	Koordinat Awal :	-7,047765	LS	110,404309	BT	Dari (Kota Asal/Km.No) : SMG
	Koordinat Akhir :	-7,047765	LS	110,404309	BT	Km. (Jarak dari kota asal) : 0+270
Tanggal Pemeriksaan Thursday, May 9, 2024	Nama Pemeriksa / NIP GENDUT SUMANTO				Tahun Pembangunan	
Nilai Traffic :	0.642997	LHR :	2709,144434		Tahun : 2019	

### USULAN PEMERIKSAAN KHUSUS

Apakah tindakan darurat disarankan ?	Ya	Tidak
--------------------------------------	----	-------

#### Elemen elemen yang memerlukan Pemeriksaan Khusus

Kode	Elemen Uraian	Lokasi				Alasan untuk melakukan pemeriksaan khusus
		A/P/B	X	Y	Z	

### TINDAKAN DARURAT

Apakah tindakan darurat disarankan ?	Ya	Tidak
--------------------------------------	----	-------

#### Elemen elemen yang memerlukan Tindakan Darurat

Kode	Elemen Uraian	Lokasi				Alasan untuk melakukan pemeriksaan khusus
		A/P/B	X	Y	Z	
4.621	Struktur Sandaran Railling					Tidak berfungsi atau tidak sesuai penempatannya

#### Hanya untuk keperluan kantor

Tanggal memasukkan Data Pemeriksaan Inventarisasi Friday, May 31, 2024	Oleh : WAHYU DWIS
---------------------------------------------------------------------------	----------------------

LAPORAN PEMERIKSAAN MENDETAIL JEMBATAN

DAFTAR KERUSAKAN UNTUK LEVEL 3-5

No. Jembatan	KT	3	3	0	7	4	1	2	0	0	0	3	0	0	2
--------------	----	---	---	---	---	---	---	---	---	---	---	---	---	---	---

EVALUASI ELEMEN

Elemen	Kode	Uraian Level 2 (pilihan)	Elemen	Kode	Uraian Level 3 (pilihan)	Kode	Uraian (pilihan)	Kerusakan	Kode	Uraian (pilihan)	Lokasi																
											Level 5					Level 4											
											A/P/B	X	Y	Z	S	R	K	F	P	NK	S	R	K	F	P	NK	
2.100	Jalan Pendekat	3.110	Perkerasan Jalan Pendekat	4.111	Perkerasan Fleksibel Jalan Pendekat	722	Permukaan yang kasar/ bertubang (debondine. aus) atau retak					1	1	0	0	0	2	1	1	0	0	0	2				
				4.112	Perkerasan Kaku Jalan Pendekat																						
				4.113	Pelat Injak																						
				4.114	Sleeper Slab																						
				4.115	Drainase Perkerasan																						
		3.120	Tanah Timbunan	4.121	Tanah Timbunan																						
				4.122	Timbunan Ringan																						
				4.123	Geosintetik																						
				4.124	Drainase Tanah Timbunan																						
		3.130	Struktur Penahan Tanah Jalan Pendekat	4.131	Dinding Penahan Tanah Tanah																						
				4.132	Bertulang/Mechanically Stabilized Earth (MSE)																						
				4.133	Drainase Struktur Penahan Tanah																						
				4.134	Soil nailing																						
		3.140	Pengaman lalu - lintas	4.141	Tiang Pengaman Jalan Pendekat																						
4.142	Pagar Pengaman/Guardrail Jalan Pendekat																										
2.200	Aliran Sungai	3.210	Aliran Sungai	4.211	tebing sungai	101	Penurunan mutu bata atau batu, atau keretakan					1	1	0	0	0	2	1	1	0	0	0	2				
				4.212	aliran air utama	501	Pendangkalan sungai akibat endapan (acradasi)							1	1	0	0	0	2	1	1	0	0	0	2		
				4.213	daerah gerangan banjir																						
		3.220	Bangunan Pengaman	4.221	Pengaman Aliran Sungai																						
				4.222	Pengaman Tebing Sungai	101	Penurunan mutu bata atau batu, atau keretakan							1	1	0	0	0	2	1	1	0	0	0	2		
				4.223	Pengaman Bangunan Bawah																						
				4.224	Perkuatan bangunan Pengaman																						
2.300	Bangunan Bawah	3.310	Pondasi	4.311	Fondasi Tiang																						
				4.312	Fondasi Sumuran																						
				4.313	Fondasi Langsung									1	0	0	0	0	1	1	0	0	0	0	1		
				4.314	Pondasi Balok Pelengkung																						
				4.315	Sambungan Fondasi dan Lainnya																						
				4.316	Perkuatan Fondasi																						
				4.317	Struktur jembatan apung																						
		3.320	Kepala Jembatan/Pilar	4.321	Balok Fondasi																						
				4.322	Dinding kepala jembatan / pilar	101	Penurunan mutu bata atau batu, atau keretakan							1	1	0	0	0	2	1	1	0	0	0	2		
				4.323	Balok Kepala Jembatan/Pilar																						
				4.324	Struktur penguat																						
				4.325	Sambungan kepala jembatan / pilar																						
				4.326	Perkuatan bangunan bawah																						
				4.327	Drainase Kepala jembatan / pilar																						
2.400	Bangunan Atas	3.410	Sistem Gelagar	4.411	Gelagar utama																						
				4.412	Diafragma																						
				4.413	Pengaku gelagar baja																						
				4.414	Perkuatan selagar																						
				4.415	Sambungan selagar																						
				4.416	Drainase Gelagar																						
				3.420	Jembatan Pelat	4.421	pelat beton bertulang																				
		4.422	Pelat beton pracetak																								
		4.423	Kabel prategang melintang																								
		4.424	Shear key (sambungan antar pelat beton pracetak/pratekan - flat slab )																								
		4.425	Perkuatan Jembatan Pelat																								
		4.426	Drainase Jembatan Pelat																								
		3.430	Pelengkung			4.431	Pelengkung																				
				4.432	Dinding pelengkung																						
4.433	Perkuatan pelengkung																										
4.434	Drainase Pelengkung																										

LEVEL 3		Nilai Kondisi					
Kode	Elemen	S	R	K	F	P	NK
3.110	Perkerasan Jalan Pendekat	1	1	0	0	0	2
3.120	Tanah Timbunan						-
3.130	Struktur Penahan Tanah Jalan Pendekat						-
3.140	Pengaman lalu-lintas	1	0	0	0	0	1
3.210	Aliran Sungai	1	1	0	0	0	2
3.220	Bangunan Pengaman	1	1	0	0	0	2
3.310	Fondasi	1	0	0	0	0	1
3.320	Kepala Jembatan/Pilar	1	1	0	0	0	2
3.410	Sistem Gelagar	1	0	0	0	0	1
3.420	Jembatan Pelat						-
3.430	Pelengkung						-
3.440	Balok Pelengkung						-
3.450	Rangka						-
3.460	Jembatan Beruji Kabel (Cable-Stayed)						-
3.470	Jembatan Gantung						-
3.480	Pilon						-
3.490	Gelagar Boks						-
3.500	Sistem Lantai	1	1	0	0	0	2
3.600	Sambungan / Star muai						-
3.610	Perletakan						-
3.620	Pengaman Pengguna Jalan	1	1	1	0	1	4
3.630	Perlengkapan Aerodinamik Jembatan						-
3.710	Perlengkapan Umum						-
3.720	Penerangan						-
3.730	Utilitas	1	0	0	0	0	1
3.740	Pengaman struktur dan lingkungan						-
3.750	SMKS (Sistem Monitoring Kesehatan Jembatan)						-
3.760	Perlengkapan Jembatan Gerak/movable bridge						-
3.770	Fasilitas Pemeriksaan Tetap						-
3.810	Tanah di dalam struktur Gorong-gorong						-
3.820	Gorong - gorong persegi Boks						-
3.830	Gorong - gorong pipa						-
3.840	Gorong - gorong Pelengkung Baja Gelombang						-
3.850	Struktur Pendukung Gorong-gorong						-
3.860	Perkuatan gorong - gorong						-
3.910	Lintasan dengan perkerasan						-
3.920	Lintasan alam (tanpa perkerasan)						-
3.930	Lintasan dengan struktur semi - permanen						-

LEVEL 2		Nilai Kondisi					
Kode	Elemen	S	R	K	F	P	NK
2.100	Jalan Pendekat	1	1	0	0	0	2
2.200	Aliran Sungai	1	1	0	0	0	2
2.300	Bangunan Bawah	1	1	0	0	0	2
2.400	Bangunan Atas	1	1	0	0	0	2
2.700	Perlengkapan	1	0	0	0	0	1
2.800	Gorong-gorong						-
2.900	Struktur Lintasan Basah						-

LEVEL 1		Nilai Kondisi					
---------	--	---------------	--	--	--	--	--

Elemen		Elemen		Elemen		Kerusakan		Lokasi					Level 5					Level 4													
Kode	Uraian Level 2 (pilihan)	Kode	Uraian Level 3 (pilihan)	Kode	Uraian (pilihan)	Kode	Uraian (pilihan)	A/P/B	X	Y	Z	S	R	K	F	P	NK	S	R	K	F	P	NK								
2.700	Perengkapan	3.440	Balok Pelengkung	4.441	Salok pelengkung																										
				4.442	Pengaku Balok Pelengkung																										
				4.443	Sambungan Balok Pelengkung																										
				4.444	Balok Pelengkung Rangka Baja																										
				4.445	Pengantungan Rangka Baja																										
				4.446	Perkuatan Balok Pelengkung																										
				4.447	Drainase Balok Pelengkung																										
				3.450	Rangka	4.451	Rangka Jembatan Panel																								
						4.451	Rangka Jembatan Panel																								
						4.452	Sambungan Rangka Jembatan Panel																								
						4.453	Struktur Rangka																								
						4.454	Pengaku Rangka																								
						4.455	Sambungan Rangka Baja																								
						4.456	Perkuatan Jembatan Rangka																								
				3.460	Jembatan - Beruji - Kabel (Cable-stayed)	4.461	Sistem Kabel Jembatan-Beruji-Kabel																								
		4.462	Sistem Penahan Kabel Jembatan-beruji-kabel																												
		4.463	Gelagar Melintang Jembatan Beruji Kabel (Cable stayed)																												
		4.464	Perkuatan Jembatan Beruji Kabel (Cable stayed)																												
		3.470	Jembatan Gantung	4.471	Sistem Kabel Jembatan Gantung																										
				4.472	Batang Penggantungan Jembatan Gantung																										
				4.473	Pengaku Jembatan Gantung																										
				4.474	Sistem penahan Kabel Jembatan Gantung																										
				4.475	Perkuatan Jembatan Gantung																										
				4.486	salok pylon																										
				4.487	salok melintang																										
				4.488	batan angin bawah																										
				4.489	gantung/sambungan																										
				3.480	Pilon	4.481	Struktur Pilon																								
		4.482	Penahan Kabel di Pilon																												
		4.483	Pilon Baja																												
		4.484	Sambungan Pilon Baja																												
		4.485	Perkuatan Pilon																												
		4.486	Drainase Pilon																												
		3.490	Gelagar Boks	4.491	Struktur Gelagar Boks																										
				4.492	Pengaku gelagar boks																										
				4.493	Sambungan Gelagar Boks																										
				4.494	Prategang Eksternal dalam gelagar boks																										
				4.495	Perkuatan selagar boks																										
				4.496	Drainase Gelagar Boks																										
		3.500	Sistem Lantai	4.511	Struktur Lantai	201	Cacat pada beton termasuk beton rontok / spalling, keropos, berongga, dan kualitas beton yang rendah							1	1	0	0	0	2	1	1	0	0	0	0	2					
				4.512	Pemvasea Sistem Lantai																										
				4.513	Trottoar dan kerb																										
				4.514	Lapis Permukaan Sistem Lantai	201	Cacat pada beton termasuk beton rontok / spalling, keropos, berongga, dan kualitas beton yang rendah								1	1	0	0	0	2	1	1	0	0	0	0	2				
				4.515	Perkuatan Sistem Lantai																										
				4.516	Link Slab																										
				4.517	Drainase Lantai																										
		3.600	Sambungan/Siar Muai	4.601	Sambungan/Siar Muai Baja (tipe ecratai)																										
				4.602	Sambungan/Siar Muai Baja Siku Profil Terbuka																										
		3.610	Landasan/Perletakan	4.611	Landasan																										
4.612	Peredam Pasif/Damping Struktur																														
4.613	Peredam Aktif Struktur																														
4.614	Pendukung landasan																														
4.615	Penahan pergerakan landasan																														
4.616	Batan / Perletakan Lainnya																														
3.620	Pengaman Pengguna Jalan	4.621	Struktur Sandaran Railing	931	Tidak berfungsi atau tidak sesuai penempatannya							1	1	1	0	1	4	1	1	1	0	1	4								
		4.622	Struktur tembok																												
		4.623	Pembatas lainnya																												
3.630	Perlengkapan Aerodinamik Jembatan	4.631	Perlengkapan Aerodinamik Bangunan Atas																												
		4.632	Perlengkapan Aerodinamik Permukaan Kabel Jembatan																												
		4.633	Wind Barrier																												
2.700	Perengkapan	3.710	Perlengkapan Umum	4.711	Perangkat Pengendali Lalu Lintas																										

LEVEL 3		Nilai Kondisi				
Kode	Elemen	S	R	K	F	NK
Kode	Elemen	S	R	K	F	NK
1,000	Jembatan	1	1	0	0	2

Elemen		Elemen		Elemen		Kerusakan		Lokasi					Level 5					Level 4							
Kode	Uraian Level 2 (pilihan)	Kode	Uraian Level 3 (pilihan)	Kode	Uraian (pilihan)	Kode	Uraian (pilihan)	A/P/B	X	Y	Z	S	R	K	F	P	NK	S	R	K	F	P	NK		
				4.712	Penanda Jembatan																				
				4.713	Penunjang Perlekapan																				
				4.714	Struktur Penutup Jembatan																				
				4.715	Pendukung sandaran / median																				
				4.721	Sistem penerangan																				
		3.720	Penerangan	4.721	Sistem penerangan																				
				4.722	Struktur Tiang Penunjang																				
				4.723	Penunjang Penerangan																				
		3.730	Utilitas	4.731	Utilitas Kabel Listrik																				
				4.732	Utilitas Pipa Air Minum							1	0	0	0	0	1	1	0	0	0	0	0	1	
				4.733	Utilitas Kabel Telekomunikasi																				
				7.734	Utilitas Pipa Air Kotor																				
				4.735	Utilitas Pipa Pembawa																				
				7.736	Sambungan utilitas																				
				4.737	Dudukan utilitas																				
		3.740	Pengaman Struktur dan Jalan Lingkungan	4.741	Perangkat Pengendali Kelembaban																				
				4.742	Perangkat Penangkal Petir																				
				4.743	Perangkat Perilindungan Korosi dan Biota Laut																				
				4.744	Labang Ventilasi																				
				4.745	Penutup Lubang Ventilasi																				
		3.750	SMKS (Sistem Monitoring Kesehatan Jembatan)	4.751	Sensor Struktur																				
				4.752	Perangkat Pengukur Beban Kendaraan																				
				4.753	Sensor pengukur Beban Kendaraan																				
				4.754	Dudukan lainnya																				
		3.760	Perengkapan Jembatan Gerak / moveable bridge	4.755	Perangkat Penyalur Daya																				
				4.761	Sistem penergerak fungsional																				
				4.762	Sistem Elektrik																				
				4.763	Sistem Hidrolik																				
				4.764	Sistem Mekanis																				
		3.770	Fasilitas Pemeriksaan Tetap	4.771	Tangga / Platform Pemeriksaan																				
				4.772	Lubang Masuk (gelagar, kolom)																				
				4.773	Traveler																				
2.800	gorong - gorong	3.810	Tanah di dalam struktur Gorong - gorong	4.811	Tanah timbunan di atas gorong - gorong																				
				4.812	Tanah dasar di bawah struktur gorong - gorong																				
		3.820	Gorong - gorong Persegi Boks	4.821	Dinding Tegak																				
				4.822	Pelat Bawah																				
				4.823	Pelat Atas																				
				4.824	Drainase Gorong - gorong Persegi Boks																				
		3.830	Gorong - gorong Pipa	4.831	Dinding penahan tanah timbunan																				
				4.832	Drainase Gorong - gorong Pipa																				
				4.841	Pelat Baja Gelombang																				
				4.842	Sambungan / Baut penakik																				
				4.843	Fondasi / Pelat Beton																				
				4.844	Dudukan Pelengkang Baja Gelombang																				
				4.844	Drainase Gorong gorong Pelengkang Baja Berpelombang																				
		3.850	Struktur Pendukung Gorong - gorong	4.851	Tembok Savap																				
				4.852	Tembok Kepala (Head wall) Gorong-gorong																				
				4.853	Tembok Bawah (Drop wall) Gorong-gorong																				
				4.854	Apron																				
		3.860	Perkuatan Gorong - gorong	4.861	Perkuatan dengan Lapisan Beton Tambahan																				
				4.862	Perkuatan dengan FRP																				
				4.863	Perkuatan dengan Lapisan Baja Tambahan																				
2.900	Struktur Lintasan B	3.910	Lintasan dengan Perkerasan																						
		3.920	Lintasan Alam (tampa perkerasan)																						
		3.930	Lintasan dengan struktur semi - permanen																						

LEVEL 3		Nilai Kondisi				
Kode	Elemen	S	R	K	F	NK



**PEMERINTAH KOTA SEMARANG  
DINAS PEKERJAAN UMUM**

JL. MADUKORO RAYA NO. 7, TELP. (024) 76433969, FAX. (024) 76433969 KOTA SEMARANG

NO. JEMBATAN :

KT	3	3	0	7	4	1	2	0	0	0	3	0	0	2	0
----	---	---	---	---	---	---	---	---	---	---	---	---	---	---	---

NAMA JEMBATAN :

BANGKONG 2

**POTONGAN MEMANJANG**

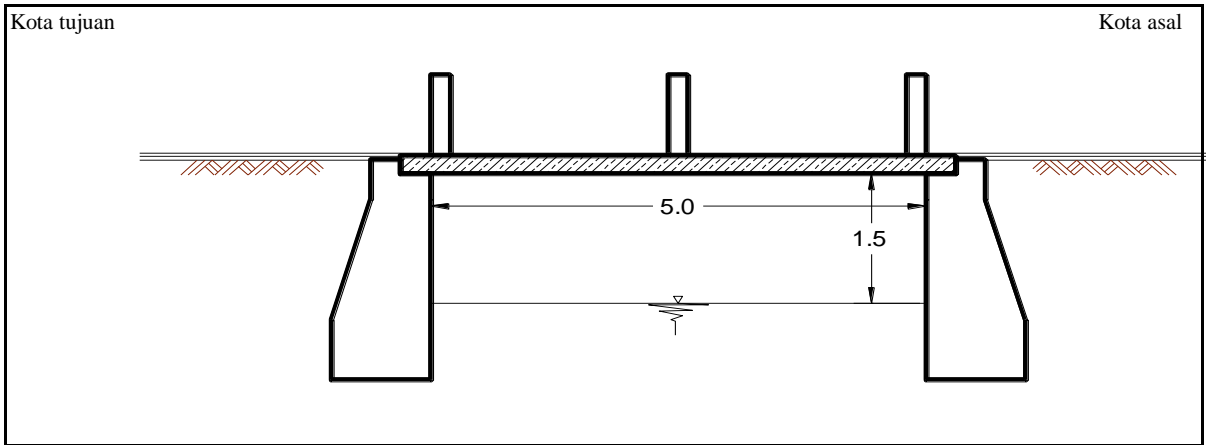

**TAMPAK ATAS**

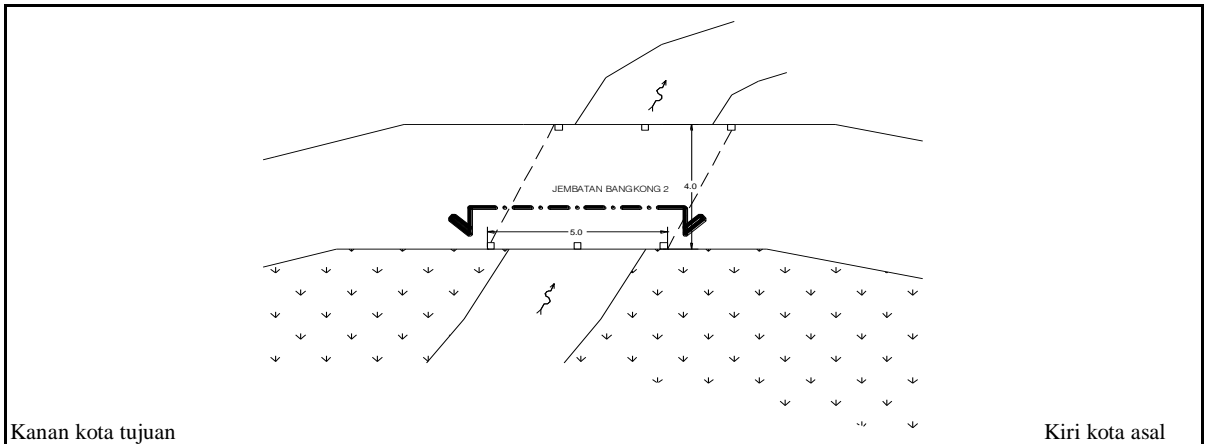

**SITUASI**

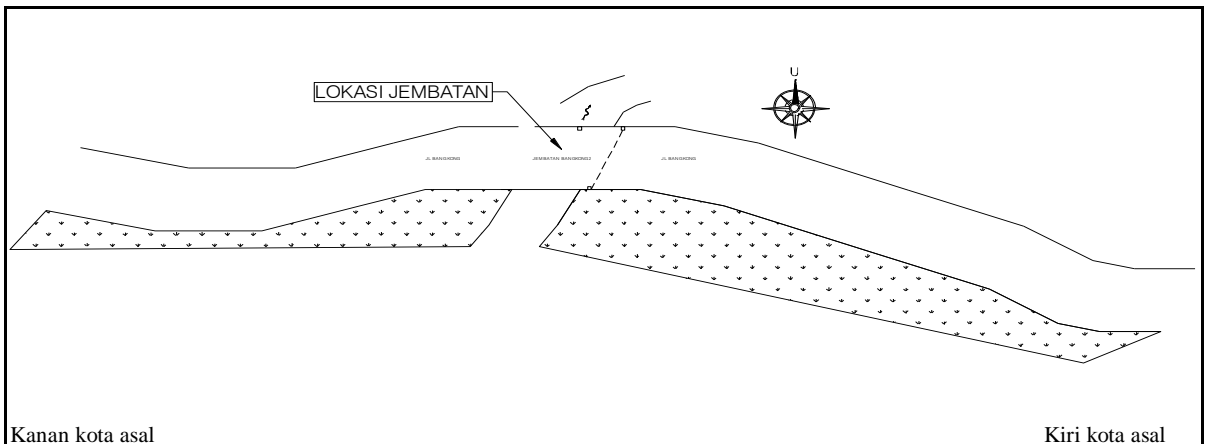



**PEMERINTAH KOTA SEMARANG**  
**DINAS PEKERJAAN UMUM**

JL. MADUKORO RAYA NO. 7, TELP. (024) 76433969, FAX. (024) 76433969 KOTA SEMARANG



**TAMPAK MEMANJANG**



**TAMPAK MEMANJANG**



**TAMPAK MELINTANG**

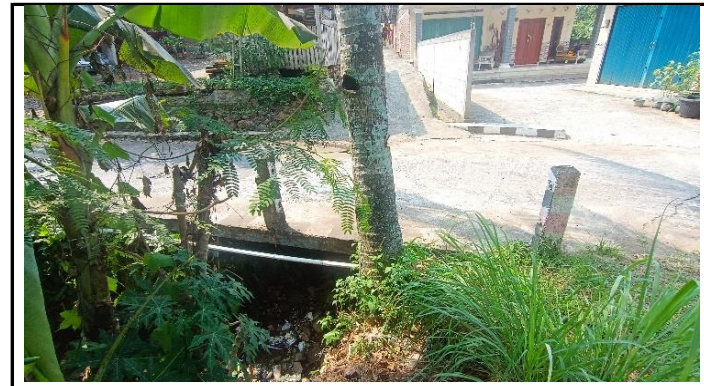

**TAMPAK MELINTANG**

<b>NOMOR JEMBATAN</b>	<b>NAMA JEMBATAN</b>	<b>LOKASI (Km)</b>	<b>PANJANG (M)</b>
KT.33.074.12.0003.002	BANGKONG 2	0+270	5,00





**PEMERINTAH KOTA SEMARANG  
DINAS PEKERJAAN UMUM**

JL. MADUKORO RAYA NO. 7, TELP. (024) 76433969, FAX. (024) 76433969 KOTA SEMARANG



**KONDISI ALIRAN SUNGAI**



**KEPALA JEMBATAN BERLUMUT DAN  
MENGALAMI PENUAAN**



**KONDISI PIPA UTILITAS AIR MINUM**



**SANDARAN JEMBATAN TERLALU RENDAH**

<b>NOMOR JEMBATAN</b>	<b>NAMA JEMBATAN</b>	<b>LOKASI ( Km )</b>	<b>PANJANG ( M )</b>
KT.33.074.12.0003.002	BANGKONG 2	0+270	5,00