



**PEMERINTAH KOTA SEMARANG
DINAS PEKERJAAN UMUM**

JL. MADUKORO RAYA NO. 7, TELP. (024) 76433969, FAX. (024) 76433969 KOTA SEMARANG

**FORM INVENTARISASI JEMBATAN
Ruas Jalan
ROWOSARI ASRI**

NO JEMBATAN : KT.33.074.10.0092.001
NAMA JEMBATAN : ROWOSARI ASRI 1
TAHUN ANGGARAN : 2024



PEMERINTAH KOTA SEMARANG
DINAS PEKERJAAN UMUM

JL. MADUKORO RAYA NO. 7, TELP. (024) 76433969, FAX. (024) 76433969 KOTA SEMARANG

SISTEM
MANAJEMEN
JEMBATAN



LAPORAN PEMERIKSAAN INVENTARISASI JEMBATAN

No. Jembatan Ruas Jalan Kabupaten dan Kota

KT	3	3	0	7	4	1	0	0	0	9	2	0	0	1	
----	---	---	---	---	---	---	---	---	---	---	---	---	---	---	--

Nama Jembatan	ROWOSARI ASRI 1				Propinsi / Kabupaten / Kota Semarang	
Lokasi Jembatan	Koordinat Awal : -7,0586050 LS	110,4823860 BT	Dari (Kota Asal/Km.No1) : SMG		Km. (Jarak dari kota asal) : 0+110	
	Koordinat Akhir : -7,0586050 LS	110,4823860 BT				
Tanggal Pemeriksaan	Nama Pemeriksa / NIP GENDUT SUMANTO				Tahun Pembangunan	
Nilai Lalu - Lintas :	0.192091	LHR : 809.34	Tahun :		2019	

INFORMASI PEMBANGUNAN JEMBATAN

1 Tanggal / Bulan / Tahun pembangunan jembatan / pengoperasian pertama kali	:	
2 Tanggal / Bulan / Tahun pelebaran/rehabilitasi/perkuatan jembatan / pengoperasian pertama kali	:	
3 Tanggal / Bulan / Tahun serah terima aset	:	
4 Penanggung jawab pembangunan (Satker/PPK)	:	
5 Penanggung jawab pelebaran/rehabilitasi/perkuatan jembatan (Satker/PPK)	:	
6 Biaya perencanaan	:	
7 Biaya pembangunan	:	
8 Biaya pelebaran/rehabilitasi/perkuatan jembatan	:	
9 Biaya pengujian	:	
10 Nilai aset serah terima	:	
11 Nama konsultan perencana pembangunan	:	
12 Nama <i>Independent Proof Checker</i> (IPC)	:	
13 Nama konsultan perencana pelebaran/rehabilitasi/perkuatan jembatan	:	
14 Nama kontraktor pelaksana pembangunan	:	
15 Nama kontraktor pelaksana pelebaran/rehabilitasi/perkuatan jembatan	:	
16 Nama subkontraktor spesialis	:	
17 Nama konsultan pengawas pembangunan	:	
18 Nama konsultan pengawas pelebaran/rehabilitasi/perkuatan jembatan	:	
19 Nama konsultan pengujian	:	
	Tersedia / Tidak	File
20 Laporan pembangunan/pelebaran/rehabilitasi/perkuatan jembatan	:	
21 <i>As-built-drawing</i> atau denah jembatan	:	

Hanya untuk keperluan kantor	
Tanggal memasukkan Data Pemeriksaan Inventarisasi 5/29/2024	Oleh : WAHYU DWIS



PEMERINTAH KOTA SEMARANG
DINAS PEKERJAAN UMUM

JL. MADUKORO RAYA NO. 7, TELP. (024) 76433969, FAX. (024) 76433969 KOTA SEMARANG

INFORMASI KAPASITAS MUATAN

1 Batasan muatan sumbu terberat MST	:	8	ton
2 Beban maksimum yang pernah di atas jembatan	:	8	ton
3 Jenis kendaraan berat yang umum lewat di atas jembatan	:	TRUK	
4 Tindakan darurat yang sedang/pernah dilakukan di atas jembatan	:	E	
a. Pembatasan beban			
b. Penyokongan/Sangga			
c. Penutupan parsial/Sebagian			
d. Penutupan penuh			
e. Jalan Memutar/ <i>detour</i>			
f. Jembatan Sementara			
5 Apakah tersedia jalan memutar/ <i>detour</i> jika jembatan ditutup		Ya	tidak
6 Panjang jarak tambahan yang harus ditempuh dengan jalan memutar		500	m

INFORMASI KAPASITAS LALU LINTAS

1 Lalu - lintas harian rata-rata tahunan (LHR) AADT	:	809.34	
2 Nilai Lalu - Lintas (Perbandingan lebar jalur lalu-lintas yang tersedia di atas jembatan dengan lebar perkerasan sebelum masuk ke dalam jembatan			
Longgar kendaraan bebas melintas di atas jembatan		0	
Cukup lebar kendaraan melaju perlahan di atas jembatan		3	
Sempit kendaraan harus antri atau berhenti		5	
3 Lebar kendaraan maksimum (<i>ODOL/Over-dimension overload vehicle</i>)	:	2,4	m

INFORMASI BATASAN PERLINTASAN DAN LINGKUNGAN

1 Tinggi muka air banjir terhadap bagian atas lantai jembatan	:	2,8	m
2 Tinggi muka air banjir terhadap elevasi perletakan jembatan	:	-	m
3 Tinggi muka air banjir terhadap elevasi terbawah bangunan atas jembatan	:	2,5	m
4 Kedalaman gerusan di sekitar pilar	:	-	m
5 Kedalaman gerusan di sekitar kepala jembatan	:	-	m
6 Kedalaman gerusan di sekitar tanah timbunan atau bangunan pengaman lainnya	:	-	m
7 Tinggi bebas perlintasan <i>overpass</i> jalan	:	-	m
8 Tinggi bebas perlintasan kereta api	:	-	m
9 Tinggi bagian tertinggi dari kapal laut dan/atau angkutannya terhadap elevasi terbawah bangunan atas jembatan	:	-	m
10 Lebar alur pelayaran untuk dibandingkan dengan kapal laut	:	-	m
11 Tinggi pylon dengan batasan lintasan pesawat udara dekat bandara	:	-	m



PEMERINTAH KOTA SEMARANG
DINAS PEKERJAAN UMUM

JL. MADUKORO RAYA NO. 7, TELP. (024) 76433969, FAX. (024) 76433969 KOTA SEMARANG

KODE-KODE PEMERIKSAAN INVENTARISASI JEMBATAN

Tipe Lintasan		JN (jalan)	SL (sungai lurus)	SM (sungai meander)	SB (sungai berjaln)	S/T (selat atau teluk)	KA (Kereta Api)	L (lain-lain)						
A. TBA (Tipe Bangunan Atas)		B. BHN (Bahan)			C1. SBA (Sifat Bangunan Atas)		C2. Keterangan Detail		D. TF (Tipe Fondasi)		E. KJP (Kepala Jembatan/Pilar)			
B	gorong-gorong persegi	K	Kayu	P	Permanen	A	Australia	CA	Cakar Ayam	A	Cap (Kepala tiang)			
Y	gorong-gorong pipa	S	Pasangan bata	S	Semi Permanen	T	Australia (Sementara)	LS	Langsung	B	Dinding penuh			
A	gorong-gorong pelengkung	M	Pasangan batu	W	Darurat	B	Belanda (tipe baru)	TP	Tiang Pancang	K	Kepala jembatan khusus			
T	gantung	G	Bronjong dan sejenisnya	X	Tidak ada struktur	D	Belanda (tipe lama)	PB	Tiang Bor	Pilar				
C	Jembatan Gantungan / Beruji Kabel (Cable Stayed)	H	Pasangan batu kosong	M	Bergerak	I	Indonesia	TU	Tiang Ulir					
G	gelagar	D	Beton tak bertulang	F	Apung	J	Jepang	SU	Sumuran	PILON				
M	gelagar komposit	T	Beton bertulang			R	Austria	LL	Lain-lain					
O	Gelagar Boks	P	Beton pratekan			E	Spanyol	A Tipe A D Tipe Diamond H Tipe H I Tipe Tunggal / I Y Tipe Y V Tipe V terbuka W Tipe Double I		C	Cap (kepala tiang)			
Q	Gelagar tipe U	B	Baja			U	Callender Hamilton (UK/Inggris)			P	Dinding penuh	S	Satu kolom	
L	balok pelengkung	U	Pelat baja gelombang			W	Acrow/Bailey	D	Dua kolom	D	Dua kolom			
E	pelengkung	Y	Komposit Baja - beton			Catatan : <i>Asal produksi jembatan, apabila diketahui pasti, dari pemeriksaan detail dapat dituliskan atau diganti dengan sifat apabila tidak pasti</i>		H	Tipe H	T	Tiga atau lebih kolom			
D	Flat Slab	J	Aluminium					I	Tipe Tunggal / I	L	Lain-lain	L	Lain-lain	
V	Voided Slab	E	Neoprene / karet					Y	Tipe Y	V	Tipe V terbuka	V	Tipe V	
R	rangka	F	Teflon					Tiang Sandaran			TB	tiang beton sandaran baja		
P	Pelat	V	PVC								BB	tiang baja sandaran baja	DB	dinding bagian bawah + sandaran baja
F	ferry	N	geotextile					DD	Sandaran/Median beton bertulang	KK	tiang kayu sandaran kayu			
K	lintasan kereta api	O	Tanah biasa/lempung atau timbunan											
W	lintasan basah	A	Aspal											
U	lain-lain	R	kerikil/pasir											
		W	Macadam											
		X	Bahan asli											
		L	Lain-lain											



PEMERINTAH KOTA SEMARANG
DINAS PEKERJAAN UMUM

JL. MADUKORO RAYA NO. 7, TELP. (024) 76433969, FAX. (024) 76433969 KOTA SEMARANG

NO. JEMBATAN :

KT	3	3	0	7	4	1	0	0	0	9	2	0	0	1	0
----	---	---	---	---	---	---	---	---	---	---	---	---	---	---	---

NAMA JEMBATAN :

ROWOSARI ASRI 1

POTONGAN MEMANJANG

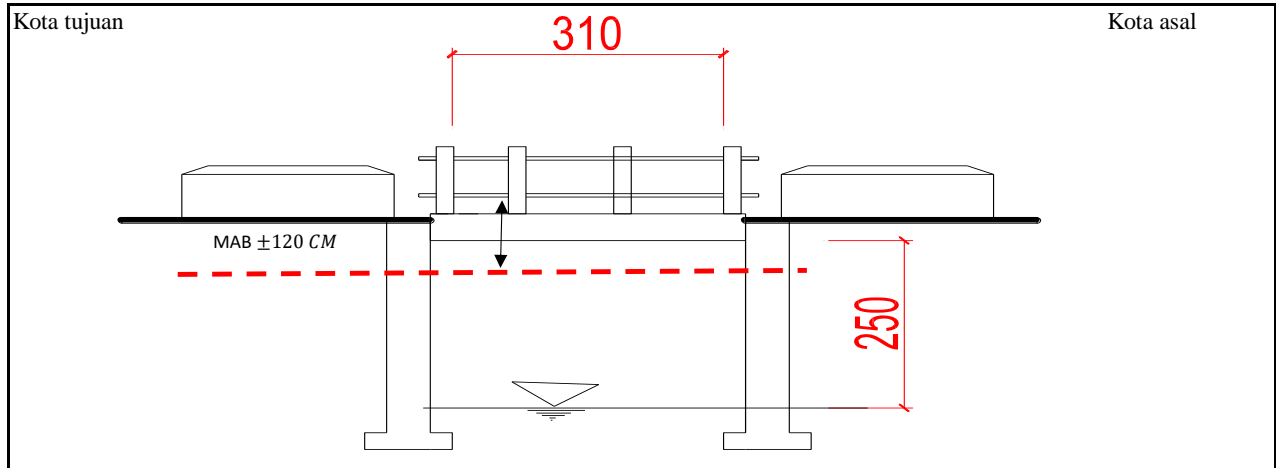

TAMPAK ATAS

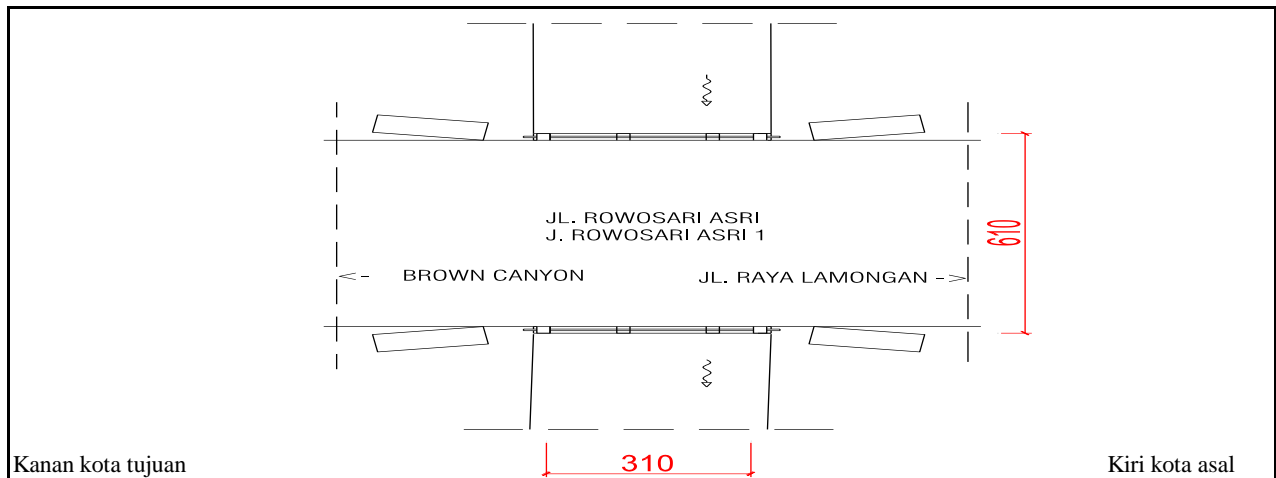

SITUASI

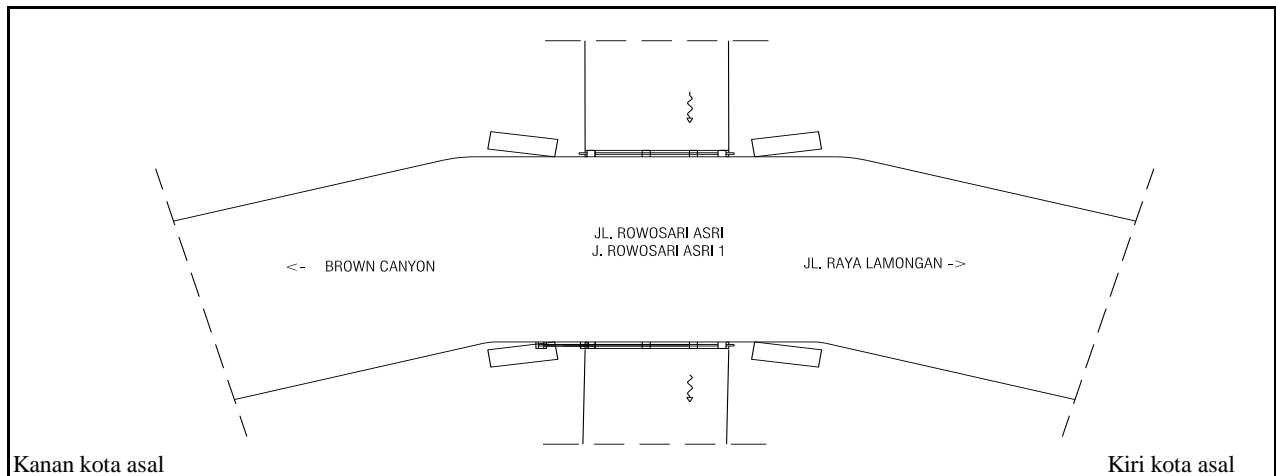



PEMERINTAH KOTA SEMARANG
DINAS PEKERJAAN UMUM

JL. MADUKORO RAYA NO. 7, TELP. (024) 76433969, FAX. (024) 76433969 KOTA SEMARANG



TAMPAK MEMANJANG



TAMPAK MEMANJANG



TAMPAK MELINTANG



TAMPAK MELINTANG

NOMOR JEMBATAN	NAMA JEMBATAN	LOKASI (Km)	PANJANG (M)
KT.33.074.10.0092.001	ROWOSARI ASRI 1	0+110	3,10



**PEMERINTAH KOTA SEMARANG
DINAS PEKERJAAN UMUM**

JL. MADUKORO RAYA NO. 7, TELP. (024) 76433969, FAX. (024) 76433969 KOTA SEMARANG



**LAPISAN PERMUKAAN LANTAI
BERGELOMBANG**



KONDISI ALIRAN SUNGAI PENUH SAMPAH



KONDISI BANGUNAN BAWAH



NOMOR JEMBATAN	NAMA JEMBATAN	LOKASI (Km)	PANJANG (M)
KT.33.074.10.0092.001	ROWOSARI ASRI 1	0+110	3,10



**PEMERINTAH KOTA SEMARANG
DINAS PEKERJAAN UMUM**

JL. MADUKORO RAYA NO. 7, TELP. (024) 76433969, FAX. (024) 76433969 KOTA SEMARANG

**FORM DETAIL JEMBATAN
Ruas Jalan
ROWOSARI ASRI**

**NO JEMBATAN : KT.33.074.10.0092.001
NAMA JEMBATAN : ROWOSARI ASRI 1
TAHUN ANGGARAN : 2024**



**PEMERINTAH KOTA SEMARANG
DINAS PEKERJAAN UMUM**

JL. MADUKORO RAYA NO. 7, TELP. (024) 76433969, FAX. (024) 76433969 KOTA SEMARANG

SISTEM
MANAJEMEN
JEMBATAN



LAPORAN PEMERIKSAAN DETAIL JEMBATAN

No. Jembatan Ruas Jalan Kabupaten dan Kota

KT	3	3	0	7	4	1	0	0	0	9	2	0	0	1	0
----	---	---	---	---	---	---	---	---	---	---	---	---	---	---	---

Nama Jembatan	ROWOSARI ASRI 1				Propinsi / Kabupaten / Kota Semarang	
Lokasi Jembatan	Koordinat Awal :	-7,058605	LS	110,482386	BT	Dari (Kota Asal/Km.NoI) : SMG
	Koordinat Akhir :	-7,058605	LS	110,482386	BT	Km. (Jarak dari kota asal) : 0+110
Tanggal Pemeriksaan Saturday, January 0, 1900	Nama Pemeriksa / NIP GENDUT SUMANTO				Tahun Pembangunan	
Nilai Traffic :	0.192091	LHR :	809.34	Tahun : 2019		

USULAN PEMERIKSAAN KHUSUS

Apakah tindakan darurat disarankan ?	Ya	Tidak
--------------------------------------	----	--------------

Elemen elemen yang memerlukan Pemeriksaan Khusus

Kode	Elemen Uraian	Lokasi				Alasan untuk melakukan pemeriksaan khusus
		A/P/B	X	Y	Z	

TINDAKAN DARURAT

Apakah tindakan darurat disarankan ?	Ya	Tidak
--------------------------------------	-----------	-------

Elemen elemen yang memerlukan Tindakan Darurat

Kode	Elemen Uraian	Lokasi				Alasan untuk melakukan pemeriksaan khusus
		A/P/B	X	Y	Z	
4.111	Perkerasan Fleksibel Jalan Pendekat					Permukaan yang kasar/ berlubang (debonding, aus) atau retak
4.322	Dinding kepala jembatan / pilar					Penurunan mutu bata atau batu, atau keretakan
4.421	pelat beton bertulang					Cacat pada beton termasuk beton rontok / spalling, keropos, berongga, dan kualitas beton yang rendah
4.511	Struktur Lantai					Permukaan yang kasar/ berlubang (debonding, aus) atau retak
4.514	Lapis Permukaan Sistem Lantai					Permukaan yang kasar/ berlubang (debonding, aus) atau retak
4.621	Struktur Sandaran Railling					Penurunan mutu atau kinerja proteksi korosi (lapisan pelindung / cat)

Hanya untuk keperluan kantor

Tanggal memasukkan Data Pemeriksaan Inventarisasi Wednesday, May 29, 2024	Oleh : WAHYU DWIS
--	----------------------

LAPORAN PEMERIKSAAN MENDETAIL JEMBATAN

DAFTAR KERUSAKAN UNTUK LEVEL 3-5

No. Jembatan	KT	3	3	0	7	4	1	0	0	0	9	2	0	0	1
--------------	----	---	---	---	---	---	---	---	---	---	---	---	---	---	---

EVALUASI ELEMEN

Elemen	Kode	Uraian Level 2 (pilihan)	Elemen	Kode	Uraian Level 3 (pilihan)	Kode	Uraian (pilihan)	Kode	Uraian (pilihan)	Lokasi															
										Level 5					Level 4										
										A/P/B	X	Y	Z	S	R	K	F	P	NK	S	R	K	F	P	NK
2.100	Jalan Pendekat	3.110	Perkerasan Jalan Pendekat	4.111	Perkerasan Fleksibel Jalan Pendekat	722	Permukaan yang kasar/ bertulang (debonding, aus) atau retak					1	1	1	0	0	3	1	1	1	0	0	3		
				4.112	Perkerasan Kaku Jalan Pendekat																				
				4.113	Pelat Injak																				
				4.114	Sleeper Slab																				
				4.115	Drainase Perkerasan																				
		3.120	Tanah Timbunan	4.121	Tanah Timbunan																				
				4.122	Timbunan Ringan																				
				4.123	Geosintetik																				
				4.124	Drainase Tanah Timbunan																				
		3.130	Struktur Penahan Tanah Jalan Pendekat	4.131	Dinding Penahan Tanah	101	Penurunan mutu bata atau batu, atau keretakan					1	1	0	0	0	2	1	1	0	0	0	2		
				4.132	Tanah Bertulang/Mechanically Stabilized Earth (MSE)																				
				4.133	Drainase Struktur Penahan Tanah																				
				4.134	Soil nailing																				
				4.141	Tiang Pengaman Jalan Pendekat																				
3.140	Pengaman lalu - lintas	4.142	Pagar Pengaman/Guardrail Jalan Pendekat																						
		4.211	tebing sungai							1	0	0	0	0	1	1	0	0	0	0	0	1			
2.200	Aliran Sungai	3.210	Aliran Sungai	4.212	aliran air utama					1	0	0	0	0	1	1	0	0	0	0	0	1			
				4.213	daerah genangan banjir							1	0	0	0	0	1	1	0	0	0	0	0	1	
				4.221	Pengaman Aliran Sungai																				
		3.220	Bangunan Pengaman	4.222	Pengaman Tebing Sungai							1	0	0	0	0	1	1	0	0	0	0	0	1	
				4.223	Pengaman Bangunan Bawah																				
				4.224	Perkuatan bangunan Pengaman																				
				4.311	Fondasi Tiang																				
		2.300	Bangunan Bawah	3.310	Pondasi	4.312	Fondasi Sumuran																		
						4.313	Fondasi Langsung	101	Penurunan mutu bata atau batu, atau keretakan					1	1	0	0	0	2	1	1	0	0	0	2
						4.314	Pondasi Balok Pelengkung																		
4.315	Sambungan Fondasi dan Lantai																								
4.316	Perkuatan Fondasi																								
4.317	Struktur jembatan apung																								
4.321	Balok Fondasi																								
3.320	Kepala Jembatan/Pilar			4.322	Dinding kepala jembatan / pilar	101	Penurunan mutu bata atau batu, atau keretakan					1	1	1	0	0	3	1	1	1	0	0	3		
				4.323	Balok Kepala Jembatan/Pilar																				
				4.324	Struktur pengaku																				
2.400	Bangunan Atas	3.410	Sistem Gelagar	4.325	Sambungan kepala jembatan / pilar																				
				4.326	Perkuatan bangunan bawah																				
				4.327	Drainase Kepala jembatan / pilar																				
				4.411	Gelagar utama																				
				4.412	Diafragma																				
				4.413	Pengaku gelagar baja																				
		3.420	Jembatan Pelat	4.414	Perkuatan gelagar																				
				4.415	Sambungan gelagar																				
				4.416	Drainase Gelagar																				
				4.421	pelat beton bertulang	201	Cacat pada beton termasuk beton rontok / spalling, keropos, berongga, dan kualitas beton yang rendah					1	1	1	0	0	3	1	1	1	0	0	3		
				4.422	Pelat beton pracetak pratekan																				
				4.423	Kabel prategang melintang																				
				4.424	Shear key (sambungan antar pelat beton pracetak pratekan - flat slab.)																				
				4.425	Perkuatan Jembatan Pelat																				
3.430	Pelengkung	4.426	Drainase Jembatan Pelat																						
		4.431	Pelengkung																						
		4.432	Dinding pelengkung																						
		4.433	Perkuatan pelengkung																						
		4.434	Drainase Pelengkung																						

LEVEL 3		Nilai Kondisi					
Kode	Elemen	S	R	K	F	P	NK
3.110	Perkerasan Jalan Pendekat	1	1	1	0	0	3
3.120	Tanah Timbunan						-
3.130	Struktur Penahan Tanah Jalan Pendekat	1	1	0	0	0	2
3.140	Pengaman lalu-lintas						-
3.210	Aliran Sungai	1	0	0	0	0	1
3.220	Bangunan Pengaman	1	0	0	0	0	1
3.310	Fondasi	1	1	0	0	0	2
3.320	Kepala Jembatan/Pilar	1	1	1	0	0	3
3.410	Sistem Gelagar						-
3.420	Jembatan Pelat	1	1	1	0	0	3
3.430	Pelengkung						-
3.440	Balok Pelengkung						-
3.450	Rangka						-
3.460	Jembatan Beruji Kabel (Cable-Stayed)						-
3.470	Jembatan Gantung						-
3.480	Pilon						-
3.490	Gelagar Boks						-
3.500	Sistem Lantai	1	1	1	0	0	3
3.600	Sambungan / Siar muai						-
3.610	Perletakan						-
3.620	Pengaman Pengguna Jalan	1	1	1	0	0	3
3.630	Perlengkapan Aerodinamik Jembatan						-
3.710	Perlengkapan Umum						-
3.720	Penerangan						-
3.730	Utilitas						-
3.740	Pengaman struktur dan lingkungan						-
3.750	SMKS (Sistem Monitoring Kesehatan Jembatan)						-
3.760	Perlengkapan Jembatan Gerak/movable bridge						-
3.770	Fasilitas Pemeriksaan Tetap						-
3.810	Tanah di dalam struktur Gorong-gorong						-
3.820	Gorong - gorong persegi Boks						-
3.830	Gorong- gorong pipa						-
3.840	Gorong - gorong Pelengkung Baja Gelombang						-
3.850	Struktur Pendukung Gorong-gorong						-
3.860	Perkuatan gorong - gorong						-
3.910	Lintasan dengan perkerasan						-
3.920	Lintasan alam (tanpa perkerasan)						-
3.930	Lintasan dengan struktur semi - permanen						-

LEVEL 2		Nilai Kondisi					
Kode	Elemen	S	R	K	F	P	NK
2.100	Jalan Pendekat	1	1	1	0	0	3
2.200	Aliran Sungai	1	0	0	0	0	1
2.300	Bangunan Bawah	1	1	1	0	0	3
2.400	Bangunan Atas	1	1	1	0	0	3
2.700	Perlengkapan						-
2.800	Gorong-gorong						-
2.900	Struktur Lintasan Basah						-

LEVEL 1		Nilai Kondisi					
---------	--	---------------	--	--	--	--	--

Elemen		Elemen		Elemen		Kerusakan		Lokasi					Level 5					Level 4							
Kode	Uraian Level 2 (pilihan)	Kode	Uraian Level 3 (pilihan)	Kode	Uraian (pilihan)	Kode	Uraian (pilihan)	A/P/B	X	Y	Z	S	R	K	F	P	NK	S	R	K	F	P	NK		
		3.440	Balok Pelengkung	4.441	balok pelengkung																				
				4.442	Pengaku Balok Pelengkung																				
				4.443	Sambungan Balok Pelengkung																				
				4.444	Balok Pelengkung Rangka Baja																				
				4.445	Pengantungan Rangka Baja																				
				4.446	Perkuatan Balok Pelengkung																				
				4.447	Drainase Balok Pelengkung																				
		3.450	Rangka	4.451	Rangka Jembatan Panel																				
				4.451	Rangka Jembatan Panel																				
				4.452	Sambungan Rangka Jembatan Panel																				
				4.453	Struktur Rangka																				
				4.454	Pengaku Rangka																				
				4.455	Sambungan Rangka Baja																				
				4.456	Perkuatan Jembatan Rangka																				
				4.457	Drainase Rangka																				
		3.460	Jembatan - Beruji - Kabel (Cable-stayed)	4.461	Sistem Kabel Jembatan-Beruji-Kabel																				
				4.462	Sistem Penahan Kabel Jembatan-beruji-kabel																				
				4.463	Gelagar Melintang Jembatan Beruji Kabel (Cable stayed)																				
				4.464	Perkuatan Jembatan Beruji Kabel (Cable stayed)																				
		3.470	Jembatan Gantung	4.471	Sistem Kabel Jembatan Gantung																				
				4.472	Batang Penggantungan Jembatan Gantung																				
				4.473	Pengaku Jembatan Gantung																				
				4.474	Sistem penahan Kabel Jembatan Gantung																				
				4.475	Perkuatan Jembatan Gantung																				
				4.486	salok pylon																				
				4.487	salok melintang																				
				4.488	Batun amon bawah gantungan/sambungan																				
				4.489	gantungan/sambungan																				
		3.480	Pilon	4.481	Struktur Pilon																				
				4.482	Penahan Kabel di Pilon																				
				4.483	Pilon Baja																				
				4.484	Sambungan Pilon Baja																				
				4.485	Perkuatan Pilon																				
				4.486	Drainase Pilon																				
		3.490	Gelagar Boks	4.491	Struktur Gelagar Boks																				
				4.492	Pengaku gelagar boks																				
				4.493	Sambungan Gelagar Boks																				
				4.494	Prategang Eksternal dalam gelagar boks																				
				4.495	Perkuatan selagar boks																				
				4.496	Drainase Gelagar Boks																				
		3.500	Sistem Lantai	4.511	Struktur Lantai	722	Permukaan yang kasar/ berlubang (debonding, aus) atau retak					1	1	1	0	0	3	1	1	1	0	0	3		
				4.512	Pemangsa Sistem Lantai																				
				4.513	Trottoar dan kerb																				
				4.514	Lapis Permukaan Sistem Lantai	722	Permukaan yang kasar/ berlubang (debonding, aus) atau retak					1	1	1	0	0	3	1	1	1	0	0	3		
				4.515	Perkuatan Sistem Lantai																				
				4.516	Link Slab																				
				4.517	Drainase Lantai																				
		3.600	Sambungan/Siar Muai	4.601	Sambungan/Siar Muai Baja (tipe sercai)																				
				4.602	Sambungan/Siar Muai Baja Siku Profil Terbuka																				
		3.610	Landasan/Perletakan	4.611	Landasan																				
				4.612	Paredam Pasif/Damping Struktur																				
				4.613	Paredam Aktif Struktur																				
				4.614	Pendukung landasan																				
				4.615	Penahan pergerakan landasan																				
				4.616	Batun / Perletakan Lainnya																				
		3.620	Pengaman Pengguna Jalan	4.621	Struktur Sandaran Railling	301	Penurunan mutu atau kinerja proteksi korosi (lapisan pelindung / cat)					1	1	1	0	0	3	1	1	1	0	0	3		
				4.622	Struktur tembok	101	Penurunan mutu bata atau batu, atau keretakan					1	1	0	0	0	2	1	1	0	0	0	2		
				4.623	Pembatas lainnya																				
		3.630	Perengkapan Aerodinamik Jembatan	4.631	Perengkapan Aerodinamik Bangunan Atas																				
				4.632	Perengkapan Aerodinamik Permukaan Kabel Jembatan																				
				4.633	Wind Barrier																				
2.700	Perengkapan	3.710	Perengkapan Umum	4.711	Perangkat Pengendali Lalu Lintas																				
				4.712	Penanda Jembatan																				

LEVEL 3		Nilai Kondisi				
Kode	Elemen	S	R	K	F	NK
Kode	Elemen	S	R	K	F	NK
1,000	Jembatan	1	1	1	0	3

Elemen		Elemen		Elemen		Kerusakan		Lokasi					Level 5					Level 4						
Kode	Uraian Level 2 (pilihan)	Kode	Uraian Level 3 (pilihan)	Kode	Uraian (pilihan)	Kode	Uraian (pilihan)	A/P/B	X	Y	Z	S	R	K	F	P	NK	S	R	K	F	P	NK	
				4.713	Pemilihan Perlemakan																			
				4.714	Struktur Penutup Jembatan																			
				4.715	Pendukung sandaran / median																			
				4.721	Sistem penerangan																			
		3.720	Penerangan	4.721	Sistem penerangan																			
				4.722	Struktur Tiang Pencahayaan																			
				4.723	Pemilihan Penempatan																			
		3.730	Utilitas	4.731	Utilitas Kabel Listrik																			
				4.732	Utilitas Pipa Air Minum																			
				4.733	Utilitas Kabel Telekomunikasi																			
				7.734	Utilitas Pipa Air Kotor																			
				4.735	Utilitas Pipa Pembawa Bahan Energi lainnya																			
				7.736	Sambungan utilitas																			
				4.737	Dudukan utilitas																			
		3.740	Pengaman Struktur dan Jalan Lingkungan	4.741	Perangkat Pengendali Kelembaban																			
				4.742	Perangkat Perangkal Petir																			
				4.743	Perangkat Perlindungan Korosi dan Biota Laut																			
				4.744	Labang Ventilasi																			
				4.745	Bentur Labang Ventilasi																			
		3.750	SMKS (Sistem Monitoring Kesehatan Jembatan)	4.751	Sensor Struktur																			
				4.752	Perangkat Pengukur Beban Kendaraan																			
				4.753	Sensor pengukur Beban Kendaraan																			
				4.754	Pendukung lainnya																			
		3.760	Perlengkapan Jembatan Gerak / moveable bridge	4.755	Perangkat Penerima Data																			
				4.761	Sistem penggerak fungsional																			
				4.762	Sistem Elektrik																			
				4.763	Sistem Hidrolik																			
				4.764	Sistem Mekanis																			
		3.770	Fasilitas Pemeriksaan Tetap	4.771	Tangga / Platform Pemeriksaan																			
				4.772	Labang Masuk (gelagar, kolom)																			
				4.773	Traveler																			
2.800	gorong - gorong	3.810	Tanah di dalam struktur Gorong - gorong	4.811	Tanah timbunan di atas gorong - gorong																			
				4.812	Tanah dasar di bawah struktur gorong - gorong																			
		3.820	Gorong - gorong Persegi Boks	4.821	Dinding Tezak																			
				4.822	Pelat Bawah																			
				4.823	Pelat Atas																			
				4.824	Drainase Gorong - gorong Bersel Boks																			
		3.830	Gorong - gorong Pipa	4.831	Dinding penahan tanah timbunan																			
				4.832	Drainase Gorong - gorong Pipa																			
				4.841	Pelat Baja Gelombang																			
				4.842	Sambungan / Baut penikat																			
				4.843	Fondasi / Pelat Beton																			
				4.844	Dudukan Pelengkung Baja Gelombang																			
				4.844	Drainase Gorong gorong Pelengkung Baja Bervelombang																			
		3.850	Struktur Pendukung Gorong - gorong	4.851	Tembok Savan																			
				4.852	Tembok Kepala (Head wall) Gorong-gorong																			
				4.853	Tembok Bawah (Drop wall) Gorong-gorong																			
				4.854	Apron																			
		3.860	Perkuatan Gorong - gorong	4.861	Perkuatan dengan Lapisan Beton Tambahan																			
				4.862	Perkuatan dengan FRP																			
				4.863	Perkuatan dengan Lapisan Baja Tambahan																			
2.900	Struktur Lintasan B	3.910	Lintasan dengan Perkerasan																					
		3.920	Lintasan Alam (tumpu perkerasan)																					
		3.930	Lintasan dengan struktur semi - permanen																					

LEVEL 3		Nilai Kondisi				
Kode	Elemen	S	R	K	F	NK



**PEMERINTAH KOTA SEMARANG
DINAS PEKERJAAN UMUM**

JL. MADUKORO RAYA NO. 7, TELP. (024) 76433969, FAX. (024) 76433969 KOTA SEMARANG

NO. JEMBATAN :

KT	3	3	0	7	4	1	0	0	0	9	2	0	0	1	0
----	---	---	---	---	---	---	---	---	---	---	---	---	---	---	---

NAMA JEMBATAN :

ROWOSARI ASRI 1

POTONGAN MEMANJANG

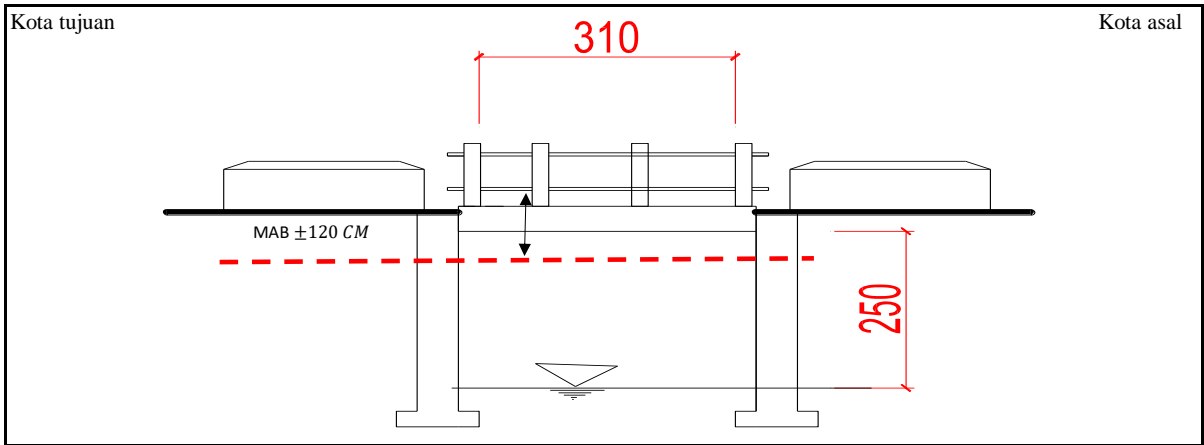

TAMPAK ATAS

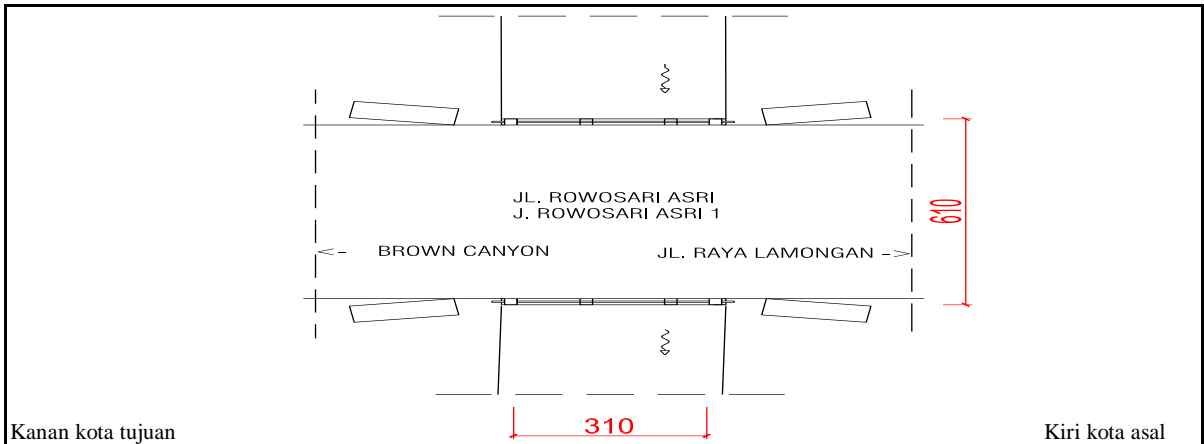

SITUASI

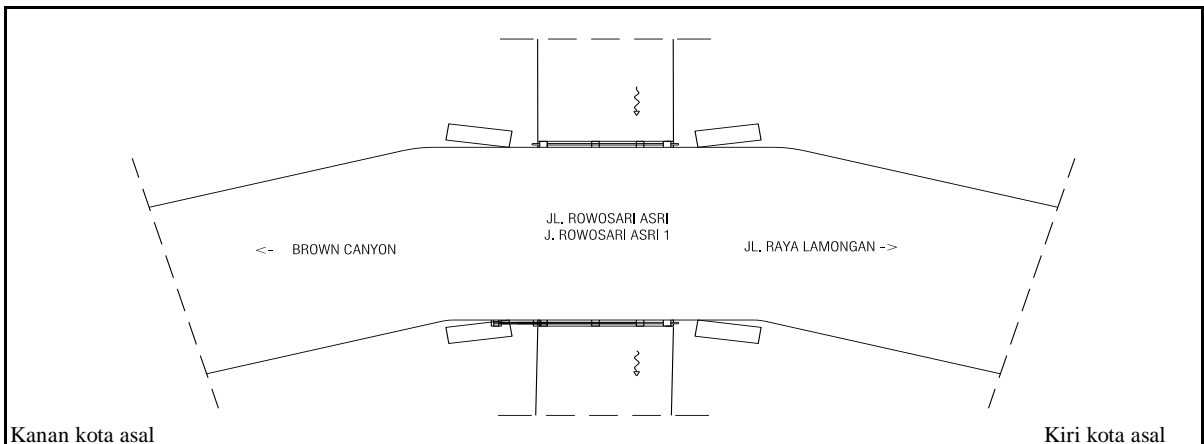



**PEMERINTAH KOTA SEMARANG
DINAS PEKERJAAN UMUM**

JL. MADUKORO RAYA NO. 7, TELP. (024) 76433969, FAX. (024) 76433969 KOTA SEMARANG



TAMPAK MEMANJANG



TAMPAK MEMANJANG



TAMPAK MELINTANG



TAMPAK MELINTANG

NOMOR JEMBATAN	NAMA JEMBATAN	LOKASI (Km)	PANJANG (M)
KT.33.074.10.0092.001	ROWOSARI ASRI 1	0+110	3,10



**PEMERINTAH KOTA SEMARANG
DINAS PEKERJAAN UMUM**

JL. MADUKORO RAYA NO. 7, TELP. (024) 76433969, FAX. (024) 76433969 KOTA SEMARANG



**LAPISAN PERMUKAAN LANTAI
BERGELOMBANG**



KONDISI ALIRAN SUNGAI PENUH SAMPAH



KONDISI BANGUNAN BAWAH



KONDISI BANGUNAN BAWAH

NOMOR JEMBATAN	NAMA JEMBATAN	LOKASI (Km)	PANJANG (M)
KT.33.074.10.0092.001	ROWOSARI ASRI 1	0+110	3,10