



**PEMERINTAH KOTA SEMARANG
DINAS PEKERJAAN UMUM**

JL. MADUKORO RAYA NO. 7, TELP. (024) 76433969, FAX. (024) 76433969 KOTA SEMARANG

**FORM INVENTARISASI JEMBATAN
Ruas Jalan
PERUM WANA MUKTI**

NO JEMBATAN : KT.33.074.10.0083.001
NAMA JEMBATAN : KETILENG LOR 1
TAHUN ANGGARAN : 2024



PEMERINTAH KOTA SEMARANG
DINAS PEKERJAAN UMUM

JL. MADUKORO RAYA NO. 7, TELP. (024) 76433969, FAX. (024) 76433969 KOTA SEMARANG

SISTEM
MANAJEMEN
JEMBATAN



LAPORAN PEMERIKSAAN INVENTARISASI JEMBATAN

No. Jembatan Ruas Jalan Kabupaten dan Kota

KT	3	3	0	7	4	1	0	0	0	8	3	0	0	1	
----	---	---	---	---	---	---	---	---	---	---	---	---	---	---	--

Nama Jembatan	KETILENG LOR 1				Propinsi / Kabupaten / Kota Semarang	
Lokasi Jembatan	Koordinat Awal : -7.030065 LS	110.466623 BT	Dari (Kota Asal/Km.No1) : SMG		Km. (Jarak dari kota asal) : 0+140	
	Koordinat Akhir : -7.030065 LS	110.466623 BT				
Tanggal Pemeriksaan 18/5/2024	Nama Pemeriksa / NIP GENDUT SUMANTO				Tahun Pembangunan -	
Nilai Lalu - Lintas :	0,102404	LHR :	431	Tahun :		2019

INFORMASI PEMBANGUNAN JEMBATAN

1 Tanggal / Bulan / Tahun pembangunan jembatan / pengoperasian pertama kali	:	-
2 Tanggal / Bulan / Tahun pelebaran/rehabilitasi/perkuatan jembatan / pengoperasian pertama kali	:	-
3 Tanggal / Bulan / Tahun serah terima aset	:	-
4 Penanggung jawab pembangunan (Satker/PPK)	:	-
5 Penanggung jawab pelebaran/rehabilitasi/perkuatan jembatan (Satker/PPK)	:	-
6 Biaya perencanaan	:	-
7 Biaya pembangunan	:	-
8 Biaya pelebaran/rehabilitasi/perkuatan jembatan	:	-
9 Biaya pengujian	:	-
10 Nilai aset serah terima	:	-
11 Nama konsultan perencana pembangunan	:	-
12 Nama <i>Independent Proof Checker</i> (IPC)	:	-
13 Nama konsultan perencana pelebaran/rehabilitasi/perkuatan jembatan	:	-
14 Nama kontraktor pelaksana pembangunan	:	-
15 Nama kontraktor pelaksana pelebaran/rehabilitasi/perkuatan jembatan	:	-
16 Nama subkontraktor spesialis	:	-
17 Nama konsultan pengawas pembangunan	:	-
18 Nama konsultan pengawas pelebaran/rehabilitasi/perkuatan jembatan	:	-
19 Nama konsultan pengujian	:	-
	Tersedia / Tidak	File
20 Laporan pembangunan/pelebaran/rehabilitasi/perkuatan jembatan	Tidak	-
21 <i>As-built-drawing</i> atau denah jembatan	Tidak	-

Hanya untuk keperluan kantor

Tanggal memasukkan Data Pemeriksaan Inventarisasi	Oleh :
25/5/2024	WAHYU DWIS



PEMERINTAH KOTA SEMARANG
DINAS PEKERJAAN UMUM

JL. MADUKORO RAYA NO. 7, TELP. (024) 76433969, FAX. (024) 76433969 KOTA SEMARANG

INFORMASI KAPASITAS MUATAN

1 Batasan muatan sumbu terberat MST	:	8	ton
2 Beban maksimum yang pernah di atas jembatan	:	8	ton
3 Jenis kendaraan berat yang umum lewat di atas jembatan	:	TRUCK	
4 Tindakan darurat yang sedang/pernah dilakukan di atas jembatan	:	C	
a. Pembatasan beban			
b. Penyokongan/Sangga			
c. Penutupan parsial/Sebagian			
d. Penutupan penuh			
e. Jalan Memutar/ <i>detour</i>			
f. Jembatan Sementara			
5 Apakah tersedia jalan memutar/ <i>detour</i> jika jembatan ditutup		Ya	tidak
6 Panjang jarak tambahan yang harus ditempuh dengan jalan memutar		1578	m

INFORMASI KAPASITAS LALU LINTAS

1 Lalu - lintas harian rata-rata tahunan (LHR) AADT	:	431	
2 Nilai Lalu - Lintas (Perbandingan lebar jalur lalu-lintas yang tersedia di atas jembatan dengan lebar perkerasan sebelum masuk ke dalam jembatan			
Longgar kendaraan bebas melintas di atas jembatan		0	
Cukup lebar kendaraan melaju perlahan di atas jembatan		3	
Sempit kendaraan harus antri atau berhenti		5	
3 Lebar kendaraan maksimum (<i>ODOL/Over-dimension overload vehicle</i>)	:	2.50	m

INFORMASI BATASAN PERLINTASAN DAN LINGKUNGAN

1 Tinggi muka air banjir terhadap bagian atas lantai jembatan	:	4.00	m
2 Tinggi muka air banjir terhadap elevasi perletakan jembatan	:	-	m
3 Tinggi muka air banjir terhadap elevasi terbawah bangunan atas jembatan	:	3.50	m
4 Kedalaman gerusan di sekitar pilar	:	-	m
5 Kedalaman gerusan di sekitar kepala jembatan	:	-	m
6 Kedalaman gerusan di sekitar tanah timbunan atau bangunan pengaman lainnya	:	-	m
7 Tinggi bebas perlintasan <i>overpass</i> jalan	:	-	m
8 Tinggi bebas perlintasan kereta api	:	-	m
9 Tinggi bagian tertinggi dari kapal laut dan/atau angkutannya terhadap elevasi terbawah bangunan atas jembatan	:	-	m
10 Lebar alur pelayaran untuk dibandingkan dengan kapal laut	:	-	m
11 Tinggi pylon dengan batasan lintasan pesawat udara dekat bandara	:	-	m



PEMERINTAH KOTA SEMARANG
DINAS PEKERJAAN UMUM

JL. MADUKORO RAYA NO. 7, TELP. (024) 76433969, FAX. (024) 76433969 KOTA SEMARANG

KODE-KODE PEMERIKSAAN INVENTARISASI JEMBATAN

Tipe Lintasan		JN (jalan)	SL (sungai lurus)	SM (sungai meander)	SB (sungai berjaln)	S/T (selat atau teluk)	KA (Kereta Api)	L (lain-lain)						
A. TBA (Tipe Bangunan Atas)		B. BHN (Bahan)			C1. SBA (Sifat Bangunan Atas)		C2. Keterangan Detail		D. TF (Tipe Fondasi)		E. KJP (Kepala Jembatan/Pilar)			
B	gorong-gorong persegi	K	Kayu	P	Permanen	A	Australia	CA	Cakar Ayam	A	Cap (Kepala tiang)			
Y	gorong-gorong pipa	S	Pasangan bata	S	Semi Permanen	T	Australia (Sementara)	LS	Langsung	B	Dinding penuh			
A	gorong-gorong pelengkung	M	Pasangan batu	W	Darurat	B	Belanda (tipe baru)	TP	Tiang Pancang	K	Kepala jembatan khusus			
T	gantung	G	Bronjong dan sejenisnya	X	Tidak ada struktur	D	Belanda (tipe lama)	PB	Tiang Bor	Pilar				
C	Jembatan Gantungan / Beruji Kabel (Cable Stayed)	H	Pasangan batu kosong	M	Bergerak	I	Indonesia	TU	Tiang Ulir					
G	gelagar	D	Beton tak bertulang	F	Apung	J	Jepang	SU	Sumuran	PILON				
M	gelagar komposit	T	Beton bertulang			R	Austria	LL	Lain-lain					
O	Gelagar Boks	P	Beton pratekan			E	Spanyol	A Tipe A D Tipe Diamond H Tipe H I Tipe Tunggal / I Y Tipe Y V Tipe V terbuka W Tipe Double I		C	Cap (kepala tiang)			
Q	Gelagar tipe U	B	Baja			U	Callender Hamilton (UK/Inggris)			P	Dinding penuh	S	Satu kolom	
L	balok pelengkung	U	Pelat baja gelombang			W	Acrow/Bailey	D	Dua kolom	D	Dua kolom			
E	pelengkung	Y	Komposit Baja - beton			Catatan : <i>Asal produksi jembatan, apabila diketahui pasti, dari pemeriksaan detail dapat dituliskan atau diganti dengan sifat apabila tidak pasti</i>		H	Tipe H	T	Tiga atau lebih kolom			
D	Flat Slab	J	Aluminium					I	Tipe Tunggal / I	L	Lain-lain	L	Lain-lain	
V	Voided Slab	E	Neoprene / karet					Y	Tipe Y	V	Tipe V terbuka	V	Tipe V	
R	rangka	F	Teflon					Tiang Sandaran			TB	tiang beton sandaran baja		
P	Pelat	V	PVC								BB	tiang baja sandaran baja	DB	dinding bagian bawah + sandaran baja
F	ferry	N	geotextile					DD	Sandaran/Median beton bertulang	KK	tiang kayu sandaran kayu			
K	lintasan kereta api	O	Tanah biasa/lempung atau timbunan											
W	lintasan basah	A	Aspal											
U	lain-lain	R	kerikil/pasir											
		W	Macadam											
		X	Bahan asli											
		L	Lain-lain											



LAPORAN PEMERIKSAAN INVENTARISASI PELEBARAN JEMBATAN

Nama Jembatan : **KETILENG LOR 1**

Sistem Manajemen Jembatan



Tipe Lintasan (pilih JN, SL, SM, SB, S/T, KA, L)				JN	SL	SM	SB	S/T	KA	L	Jumlah Bentang :	1	Panjang Total (m) :	7.00	Bentang Terpanjang (m) :	7.00
--	--	--	--	----	----	----	----	-----	----	---	------------------	---	---------------------	------	--------------------------	------

No. Bentang	Panjang Bentang (m)	Jumlah Gelagar	Sudut / skew (derajat)	Kelengkungan/radius (m)	Lebar Lantai Kend. (m)	Lebar Trotoar (m)	Tinggi Ruang Bebas (m)	Posisi Pelebaran	Pelebaran Bangunan Atas (KIRI)				Pelebaran Bangunan Atas (KANAN)				Pilon (3.480)	Struktur Lantai (4.511)	Perkuatan Sistem Lantai (4.515)	Lapis Perkuatan Sistem Lantai (4.514)	Pengaman Pengguna Jalan (3.620)	Perletakan (3.610)	Sambungan / Stair maui (3.600)	Perengkapan Aerodinamik Jembatan (3.630)	Perkuatan Bangunan Atas (4.414; 4.425, 4.433, 4.446, 4.456, 4.464, 4.475, 4.495)	Perengkapan Umum (3.710)	Penerangan (3.720)	Utilitas (3.730)	Pengaman Struktur dan Lingkungan (3.740)	SMKS (Sistem Monitoring Kesehatan Jembatan (3.750)	Perengkapan Jembatan Gerak/moveable bridge (3.760)	Fasilitas Pemeriksaan Tetap (3.770)	Gorong-gorong (3.820, 3.830, 3.840)	Perkuatan Gorong - gorong (3.850)	Lintasan Basah (3.910, 3.920, 3.930)																															
									KIRI	KANAN	TBA	BHN	SBA	TBA	BHN	SBA																				TIPE	BHN	BHN	BHN	TBA	BHN	SBA	Kode (L4)	BHN	Kode (L4)	BHN	Kode (L4)	BHN	Kode (L4)	BHN	Kode (L4)	BHN	Kode (L4)	BHN	Kode (L4)	BHN	Kode (L4)	BHN	TBA	BHN	SBA	Kode (L4)	BHN	TBA	BHN	SBA

Catatan :
 Pengisian disesuaikan dengan kode elemen dan kode laporan inventarisasi
 L4 adalah elemen pada level 4
 (*) adalah jembatan tipe gelagar

No. Kepala Jembatan / Pilar	Bangunan Bawah (2.300)				Aliran Sungai (2.200)				Jalan Pendekat (2.100)						
	Fondasi (3.910)		Kepala Jembatan/Pilar (3.320)		Perkuatan Bangunan Bawah		Tebing Sungai (4.211)	Bangunan Pengaman (3.220)		Perkerasan Jalan Pendekat (3.110)		Tanah Timbunan (3.120)	Struktur Penahan Tanah Jalan Pendekat (3.130)	Pengaman Lalu - Lintas (3.140)	
	TIPE	BHN	TIPE	BHN	Kode (L4)	BHN	BHN	Kode (L4)	BHN	Kode (L4)	BHN	Kode (L4)	BHN	Kode (L4)	BHN
PELAKR															
Kepala Jbt A.2															

Catatan :
 Pengisian disesuaikan dengan kode elemen dan kode laporan inventarisasi
 L4 adalah elemen pada level 4
 (*) adalah jembatan tipe gelagar



**PEMERINTAH KOTA SEMARANG
DINAS PEKERJAAN UMUM**

JL. MADUKORO RAYA NO. 7, TELP. (024) 76433969, FAX. (024) 76433969 KOTA SEMARANG

NO. JEMBATAN :

KT	3	3	0	7	4	1	0	0	0	8	3	0	0	1	
----	---	---	---	---	---	---	---	---	---	---	---	---	---	---	--

NAMA JEMBATAN : KETILENG LOR 1

POTONGAN MEMANJANG

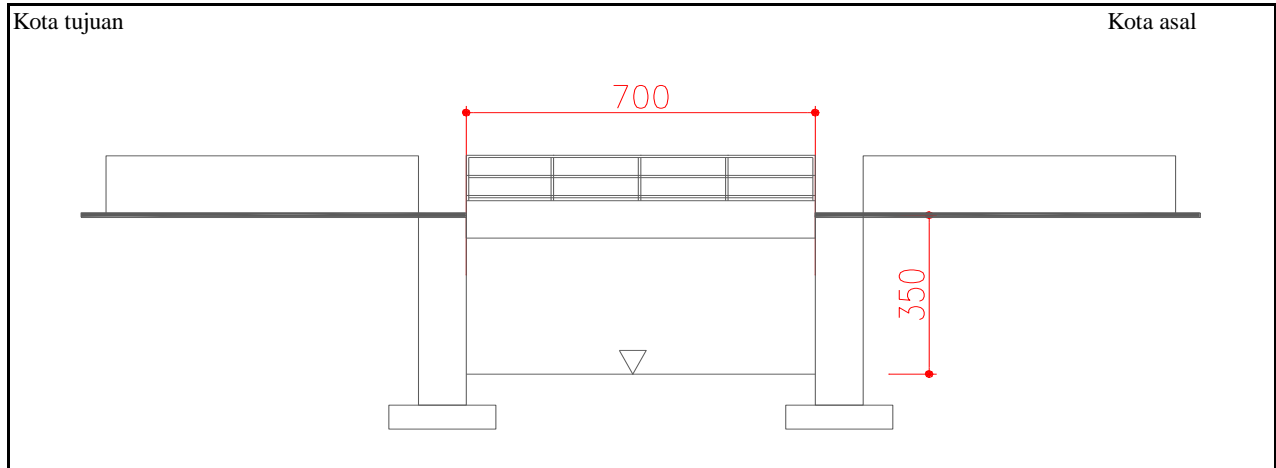

TAMPAK ATAS

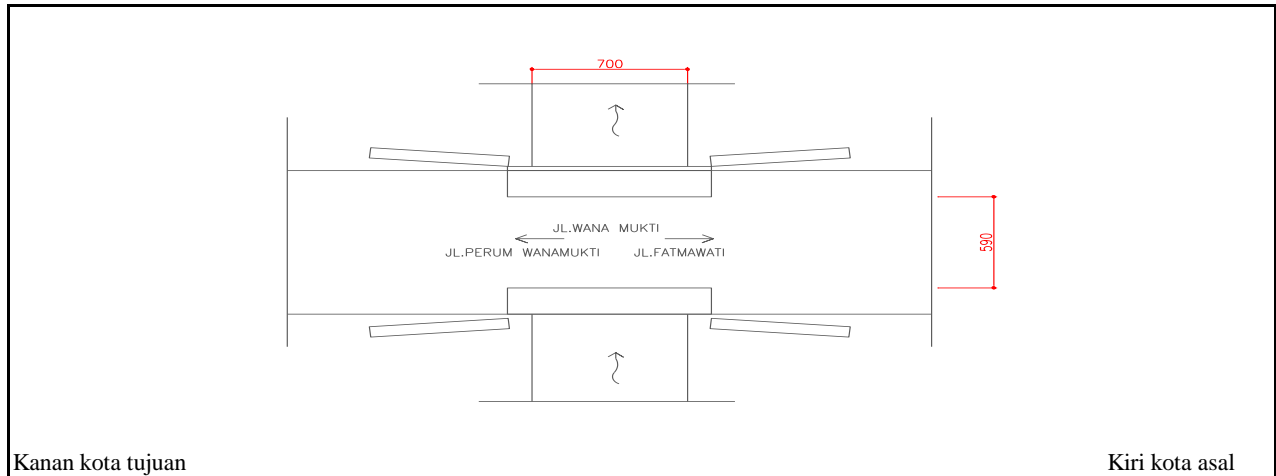

SITUASI

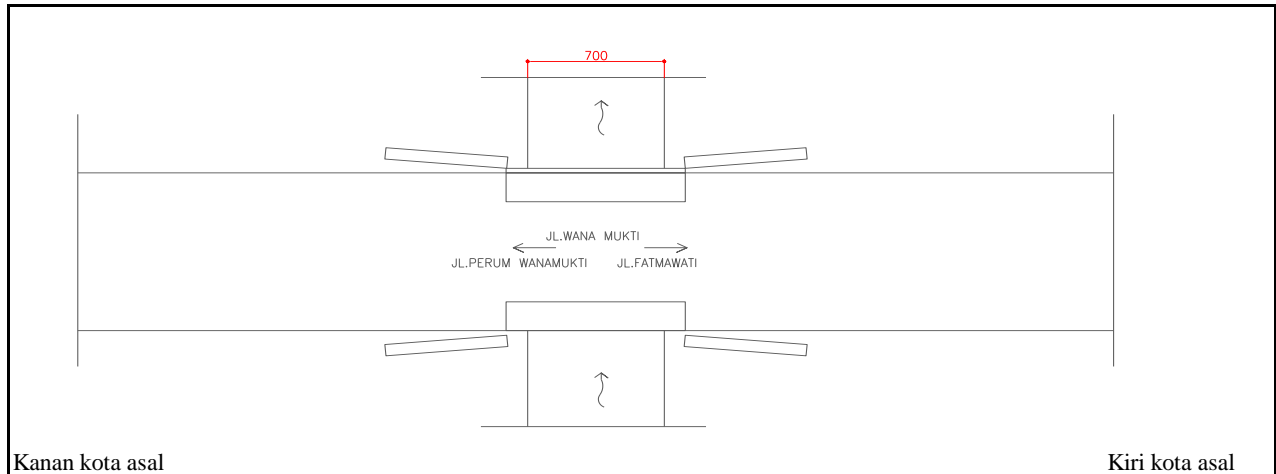



TAMPAK MEMANJANG



TAMPAK MEMANJANG



TAMPAK MELINTANG



TAMPAK MELINTANG

NOMOR JEMBATAN	NAMA JEMBATAN	LOKASI (Km)	PANJANG (M)
KT.33.074.10.0083.001	KETILENG LOR 1	0+140	7.00



**PEMERINTAH KOTA SEMARANG
DINAS PEKERJAAN UMUM**

JL. MADUKORO RAYA NO. 7, TELP. (024) 76433969, FAX. (024) 76433969 KOTA SEMARANG



KONDISI BANGUNAN BAWAH



KONDISI ALIRAN SUNGAI



TROTOAR BERLUBANG



KONDISI LAPISAN PERMUKAAN LANTAI

NOMOR JEMBATAN	NAMA JEMBATAN	LOKASI (Km)	PANJANG (M)
KT.33.074.10.0083.001	KETILENG LOR 1	0+140	7.00



**PEMERINTAH KOTA SEMARANG
DINAS PEKERJAAN UMUM**

JL. MADUKORO RAYA NO. 7, TELP. (024) 76433969, FAX. (024) 76433969 KOTA SEMARANG

**FORM DETAIL JEMBATAN
Ruas Jalan
PERUM WANA MUKTI**

**NO JEMBATAN : KT.33.074.10.0083.001
NAMA JEMBATAN : KETILENG LOR 1
TAHUN ANGGARAN : 2024**



**PEMERINTAH KOTA SEMARANG
DINAS PEKERJAAN UMUM**

JL. MADUKORO RAYA NO. 7, TELP. (024) 76433969, FAX. (024) 76433969 KOTA SEMARANG

SISTEM
MANAJEMEN
JEMBATAN



LAPORAN PEMERIKSAAN DETAIL JEMBATAN

No. Jembatan Ruas Jalan Kabupaten dan Kota

KT	3	3	0	7	4	1	0	0	0	8	3	0	0	1
----	---	---	---	---	---	---	---	---	---	---	---	---	---	---

Nama Jembatan	KETILENG LOR 1				Propinsi / Kabupaten / Kota Semarang		
Lokasi Jembatan	Koordinat Awal :	-7.030065	LS	110.466623	BT	Dari (Kota Asal/Km.No) :	SMG
	Koordinat Akhir :	-7.030065	LS	110.466623	BT	Km. (Jarak dari kota asal) :	0+140
Tanggal Pemeriksaan 18/5/2024	Nama Pemeriksa / NIP GENDUT SUMANTO				Tahun Pembangunan		
Nilai Traffic :	0,102404	LHR :	431	Tahun :		2019	

USULAN PEMERIKSAAN KHUSUS

Apakah tindakan darurat disarankan ?	Ya	Tidak
--------------------------------------	----	-------

Elemen elemen yang memerlukan Pemeriksaan Khusus

Kode	Elemen Uraian	Lokasi				Alasan untuk melakukan pemeriksaan khusus
		A/P/B	X	Y	Z	

TINDAKAN DARURAT

Apakah tindakan darurat disarankan ?	Ya	Tidak
--------------------------------------	----	-------

Elemen elemen yang memerlukan Tindakan Darurat

Kode	Elemen Uraian	Lokasi				Alasan untuk melakukan pemeriksaan khusus
		A/P/B	X	Y	Z	

Hanya untuk keperluan kantor

Tanggal memasukkan Data Pemeriksaan Inventarisasi 25/5/2024	Oleh : WAHYU DWIS
--	----------------------

Elemen		Elemen		Elemen		Kerusakan		Lokasi					Level 5					Level 4							
Kode	Urutan Level 2 (pilihan)	Kode	Urutan Level 3 (pilihan)	Kode	Urutan (pilihan)	Kode	Urutan (pilihan)	A/P/B	X	Y	Z	S	R	K	F	P	NK	S	R	K	F	P	NK		
				4.443	Sambungan Balok Pelengkung																				
				4.444	Balok Pelengkung Rangka Baja																				
				4.445	Pencantungan Rangka Baja																				
				4.446	Perkuatan Balok Pelengkung																				
				4.447	Drainase Balok Pelengkung																				
		3.450	Rangka	4.451	Rangka Jembatan Panel																				
				4.451	Rangka Jembatan Panel																				
				4.452	Sambungan Rangka Jembatan Panel																				
				4.453	Struktur Rangka Jembatan Panel																				
				4.454	Penaku Rangka																				
				4.455	Sambungan Rangka Baja																				
				4.456	Perkuatan Jembatan Rangka																				
				4.457	Drainase Rangka																				
		3.460	Jembatan - Beruji - Kabel (Cable-stayed)	4.461	Sistem Kabel Jembatan-Beruji-Kabel																				
				4.462	Sistem Penahan Kabel Jembatan-beruji-kabel																				
				4.463	Gelagar Melintang Jembatan Beruji Kabel (Cable-stayed)																				
				4.464	Perkuatan Jembatan Beruji Kabel (Cable stayed)																				
		3.470	Jembatan Gantung	4.471	Sistem Kabel Jembatan Gantung																				
				4.472	Batang Penggantung Jembatan Gantung																				
				4.473	Penaku Jembatan Gantung																				
				4.474	Sistem penahan Kabel Jembatan Gantung																				
				4.475	Perkuatan Jembatan Gantung																				
				4.486	salet pylon																				
				4.487	balok melintang																				
				4.488	ikatan angin bawah																				
				4.489	gantung/ sambungan																				
		3.480	Pilon	4.481	Struktur Pilon																				
				4.482	Penahan Kabel di Pilon																				
				4.483	Pilon Baja																				
				4.484	Sambungan Pilon Baja																				
				4.485	Perkuatan Pilon																				
				4.486	Drainase pilon																				
		3.490	Gelagar Boks	4.491	Struktur Gelagar Boks																				
				4.492	Penaku gelagar boks																				
				4.493	Sambungan Gelagar Boks																				
				4.494	Prategang Eksternal dalam gelagar boks																				
				4.495	Perkuatan gelagar boks																				
				4.496	Drainase Gelagar Boks																				
		3.500	Sistem Lantai	4.511	Struktur Lantai																				
				4.512	Pemangga Sistem Lantai																				
				4.513	Trottoar dan kerb	205	Pecah atau hilangnya bahan (delaminasi, abrasi, aus)						0	1	0	0	1	2	0	1	0	0	2	2	
				4.514	Lapis Permukaan Sistem Lantai																				
				4.515	Perkuatan Sistem Lantai																				
				4.516	Link Slab																				
				4.517	Drainase Lantai																				
		3.600	Sambungan/Siar Muai	4.601	Sambungan/Siar Muai Baja (tipe serasi)																				
				4.602	Sambungan/Siar Muai Baja Siku Profil Terbuka																				
		3.610	Landasan/Perletakan	4.611	Landasan																				
				4.612	Peredam Pasif/Damping Struktur																				
				4.613	Peredam Aktif Struktur																				
				4.614	Pendukung landasan																				
				4.615	Penahan pergerakan landasan																				
				4.616	Batan / Perletakan Lainnya																				
		3.620	Pengaman Pengguna Jalan	4.621	Struktur Sandaran Railline																				
				4.622	Struktur tembok																				
				4.623	Pembatas lainnya																				
		3.630	Perlengkapan Aerodinamik Jembatan	4.631	Perlengkapan Aerodinamik Bangunan Atas																				
				4.632	Perlengkapan Aerodinamik Permukaan Kabel Jembatan																				
				4.633	Wind Barrier																				
2.700	Perlengkapan	3.710	Perlengkapan Umum	4.711	Perangkat Pengendali Lalu Lintas																				
				4.712	Penanda Jembatan																				
				4.713	Pennunjang Perlengkapan																				
				4.714	Struktur Penutup Jembatan																				
				4.715	Pendukung sandaran / median																				
				4.721	Sistem pencahayaan																				

LEVEL 3		Nilai Kondisi				
Kode	Elemen	S	R	K	F	NK

Elemen		Elemen		Elemen		Kerusakan		Lokasi					Level 5					Level 4						
Kode	Uraian Level 2 (pilihan)	Kode	Uraian Level 3 (pilihan)	Kode	Uraian (pilihan)	Kode	Uraian (pilihan)	A/P/B	X	Y	Z	S	R	K	F	P	NK	S	R	K	F	P	NK	
		3.720	Penerangan	4.721	Sistem penerangan																			
				4.722	Struktur Tiang Pemasangan																			
				4.723	Penunjang Penerangan																			
		3.730	Utilitas	4.731	Utilitas Kabel Listrik																			
				4.732	Utilitas Pipa Air Minum							0	0	0	0	0	0	0	0	0	0	0	0	0
				4.733	Utilitas Kabel Telekomunikasi																			
				7.734	Utilitas Pipa Air Kotor																			
				4.735	Utilitas Pipa Pembawa Bahan Energi lainnya																			
				7.736	Sambungan utilitas																			
				4.737	Dudukan utilitas																			
		3.740	Pengaman Struktur dan Jalan Lingkungan	4.741	Perangkat Pengendali Kelembaban																			
				4.742	Perangkat Penangkal Petir																			
				4.743	Perangkat Perlindungan Korosi dan Biotin Laut																			
				4.744	Labang Ventilasi																			
				4.745	Penutup Lubang Ventilasi																			
		3.750	SMKS (Sistem Monitoring Kesehatan Jembatan)	4.751	Sensor Struktur																			
				4.752	Perangkat Pengukur Beban Kendaraan																			
				4.753	Sensor pengukur Beban Kendaraan																			
				4.754	Pendukung lainnya																			
		3.760	Perengkapan Jembatan Gerak / moveable bridge	4.755	Perangkat Penyalur Data																			
				4.761	Sistem penasecer fungsional																			
				4.762	Sistem Elektrik																			
				4.763	Sistem Hidrolik																			
				4.764	Sistem Mekanis																			
		3.770	Fasilitas Pemeriksaan Tetap	4.771	Tangga / Platform Pemeriksaan																			
				4.772	Labang Masuk (gelagar, kolom)																			
				4.773	Traveler																			
2.800	gorong - gorong	3.810	Tanah di dalam struktur Gorong - gorong	4.811	Tanah timbunan di atas sorong - sorong																			
				4.812	Tanah dasar di bawah struktur sorong - sorong																			
		3.820	Gorong - gorong Persegi Boks	4.821	Dinding Tesak																			
				4.822	Pelat Bawah																			
				4.823	Pelat Atas																			
				4.824	Drainase Gorong - gorong Resesi Boks																			
		3.830	Gorong - gorong Pipa	4.831	Dinding penahan tanah timbunan																			
				4.832	Drainase Gorong - gorong Pipa																			
				4.841	Pelat Bain Gelombang																			
				4.842	Sambungan / Baut penikat																			
				4.843	Fondasi / Pelat Beton Dudukan Pelengkung Baja Gelombang																			
				4.844	Drainase Gorong gorong Pelengkung Baja Bertegelombang																			
		3.850	Struktur Pendukung Gorong - gorong	4.851	Tembok Sayap																			
				4.852	Tembok Kepala (Head wall) Gorong-sorong																			
				4.853	Tembok Bawah (Drop wall) Gorong-sorong																			
				4.854	Apron																			
		3.860	Perkuatan Gorong - gorong	4.861	Perkuatan dengan Lapisan Beton Tambahan																			
				4.862	Perkuatan dengan FRP																			
				4.863	Perkuatan dengan Lapisan Baja Tambahan																			
2.900	Struktur Lintasan B	3.910	Lintasan dengan Perkerasan																					
		3.920	Lintasan Alam (tanpa perkerasan)																					
		3.930	Lintasan dengan struktur semi - perkerasan																					

LEVEL 3		Nilai Kondisi				
Kode	Elemen	S	R	K	F	NK



**PEMERINTAH KOTA SEMARANG
DINAS PEKERJAAN UMUM**

JL. MADUKORO RAYA NO. 7, TELP. (024) 76433969, FAX. (024) 76433969 KOTA SEMARANG

NO. JEMBATAN :

KT	3	3	0	7	4	1	0	0	0	8	3	0	0	1	0
----	---	---	---	---	---	---	---	---	---	---	---	---	---	---	---

NAMA JEMBATAN : KETILENG LOR 1

POTONGAN MEMANJANG

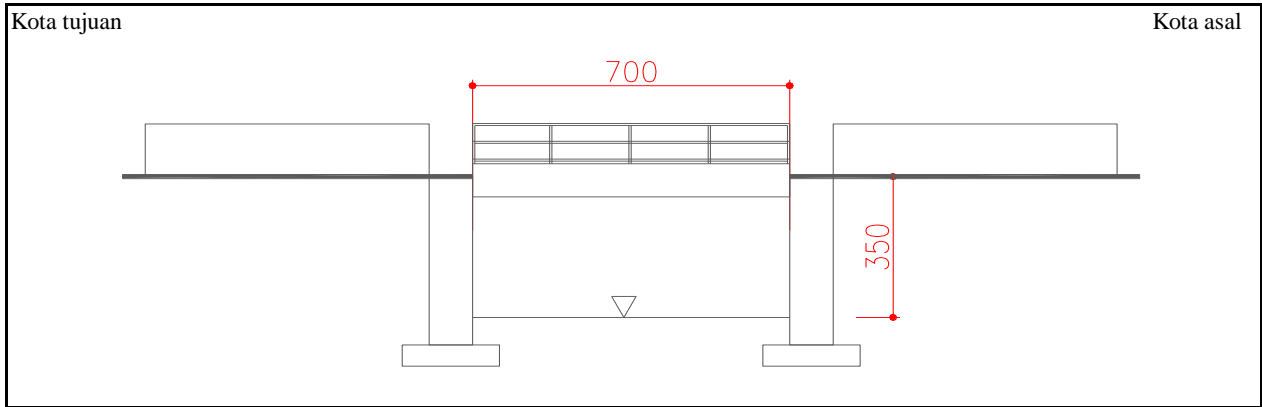

TAMPAK ATAS

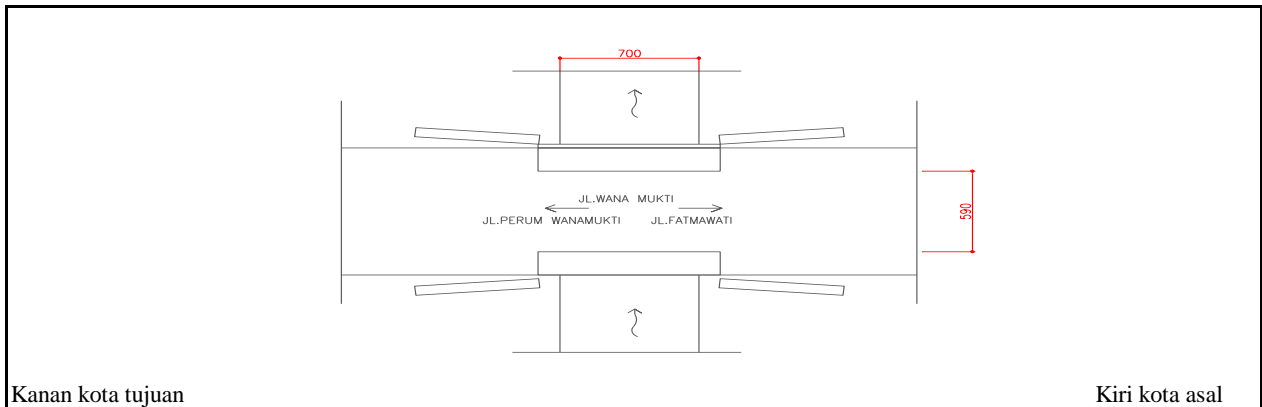

SITUASI

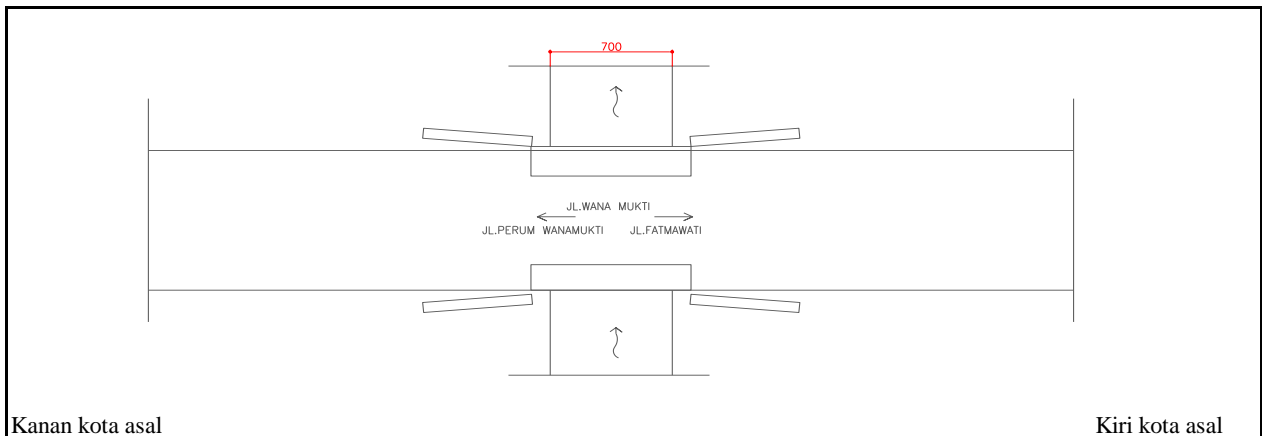



PEMERINTAH KOTA SEMARANG
DINAS PEKERJAAN UMUM

JL. MADUKORO RAYA NO. 7, TELP. (024) 76433969, FAX. (024) 76433969 KOTA SEMARANG



TAMPAK MEMANJANG



TAMPAK MEMANJANG



TAMPAK MELINTANG



TAMPAK MELINTANG

NOMOR JEMBATAN	NAMA JEMBATAN	LOKASI (Km)	PANJANG (M)
KT.33.074.10.0083.001	KETILENG LOR 1	0+140	7.00



KONDISI BANGUNAN BAWAH



KONDISI ALIRAN SUNGAI



TROTOAR BERLUBANG



KONDISI LAPISAN PERMUKAAN LANTAI

NOMOR JEMBATAN	NAMA JEMBATAN	LOKASI (Km)	PANJANG (M)
KT.33.074.10.0083.001	KETILENG LOR 1	0+140	7.00