



**PEMERINTAH KOTA SEMARANG
DINAS PEKERJAAN UMUM**

JL. MADUKORO RAYA NO. 7, TELP. (024) 76433969, FAX. (024) 76433969 KOTA SEMARANG

**FORM INVENTARISASI JEMBATAN
Ruas Jalan
SENDANGGUWO BARU**

NO JEMBATAN : KT.33.074.06.0067.001
NAMA JEMBATAN : SENDANGGUWO BARU 1
TAHUN ANGGARAN : 2024



LAPORAN PEMERIKSAAN INVENTARISASI JEMBATAN

No. Jembatan Ruas Jalan Kabupaten dan Kota

KT	3	3	0	7	4	0	6	0	0	6	7	0	0	1
----	---	---	---	---	---	---	---	---	---	---	---	---	---	---

Nama Jembatan	SENDANGGUWO BARU 1				Provinsi / Kabupaten / Kota Semarang	
Lokasi Jembatan	Koordinat Awal : -7,00793 LS	110,46143 BT	Koordinat Akhir : -7,00793 LS		110,46143 BT	Dari (Kota Asal/Km.NoI) : SMG Km. (Jarak dari kota asal) : 0+000
Tanggal Pemeriksaan 03/09/2024	Nama Pemeriksa / NIP GENDUT SUMANTO				Tahun Pembangunan -	
Nilai Lalu - Lintas :	0,072955	LHR :	307		Tahun : 2019	

INFORMASI PEMBANGUNAN JEMBATAN

1	Tanggal / Bulan / Tahun pembangunan jembatan / pengoperasian pertama kali	:	-	
2	Tanggal / Bulan / Tahun pelebaran/rehabilitasi/perkuatan jembatan / pengoperasian pertama kali	:	-	
3	Tanggal / Bulan / Tahun serah terima aset	:	-	
4	Penanggung jawab pembangunan (Satker/PPK)	:	-	
5	Penanggung jawab pelebaran/rehabilitasi/perkuatan jembatan (Satker/PPK)	:	-	
6	Biaya perencanaan	:	-	
7	Biaya pembangunan	:	-	
8	Biaya pelebaran/rehabilitasi/perkuatan jembatan	:	-	
9	Biaya pengujian	:	-	
10	Nilai aset serah terima	:	-	
11	Nama konsultan perencana pembangunan	:	-	
12	Nama <i>Independent Proof Checker</i> (IPC)	:	-	
13	Nama konsultan perencana pelebaran/rehabilitasi/perkuatan jembatan	:	-	
14	Nama kontraktor pelaksana pembangunan	:	-	
15	Nama kontraktor pelaksana pelebaran/rehabilitasi/perkuatan jembatan	:	-	
16	Nama subkontraktor spesialis	:	-	
17	Nama konsultan pengawas pembangunan	:	-	
18	Nama konsultan pengawas pelebaran/rehabilitasi/perkuatan jembatan	:	-	
19	Nama konsultan pengujian	:	-	
			Tersedia / Tidak	File
20	Laporan pembangunan/pelebaran/rehabilitasi/perkuatan jembatan	:	Tidak	-
21	<i>As-built-drawing</i> atau denah jembatan	:	Tidak	-

Hanya untuk keperluan kantor

Tanggal memasukkan Data Pemeriksaan Inventarisasi 14/3/2024	Oleh : WAHYU DWIS
----------------------------------------------------------------	----------------------



PEMERINTAH KOTA SEMARANG
DINAS PEKERJAAN UMUM

JL. MADUKORO RAYA NO. 7, TELP. (024) 76433969, FAX. (024) 76433969 KOTA SEMARANG

INFORMASI KAPASITAS MUATAN

1 Batasan muatan sumbu terberat MST	:	8	ton
2 Beban maksimum yang pernah di atas jembatan	:	8	ton
3 Jenis kendaraan berat yang umum lewat di atas jembatan	:	TRUCK	
4 Tindakan darurat yang sedang/pernah dilakukan di atas jembatan	:	C	
a. Pembatasan beban			
b. Penyokongan/Sangga			
c. Penutupan parsial/Sebagian			
d. Penutupan penuh			
e. Jalan Memutar/ <i>detour</i>			
f. Jembatan Sementara			
5 Apakah tersedia jalan memutar/ <i>detour</i> jika jembatan ditutup		Ya	tidak
6 Panjang jarak tambahan yang harus ditempuh dengan jalan memutar		50	m

INFORMASI KAPASITAS LALU LINTAS

1 Lalu - lintas harian rata-rata tahunan (LHR) AADT	:	307	
2 Nilai Lalu - Lintas (Perbandingan lebar jalur lalu-lintas yang tersedia di atas jembatan dengan lebar perkerasan sebelum masuk ke dalam jembatan		3	
Longgar kendaraan bebas melintas di atas jembatan		0	
Cukup lebar kendaraan melaju perlahan di atas jembatan		3	
Sempit kendaraan harus antri atau berhenti		5	
3 Lebar kendaraan maksimum (<i>ODOL/Over-dimension overload vehicle</i>)	:	2,5	m

INFORMASI BATASAN PERLINTASAN DAN LINGKUNGAN

1 Tinggi muka air banjir terhadap bagian atas lantai jembatan	:	2	m
2 Tinggi muka air banjir terhadap elevasi perletakan jembatan	:	1,5	m
3 Tinggi muka air banjir terhadap elevasi terbawah bangunan atas jembatan	:	-	m
4 Kedalaman gerusan di sekitar pilar	:	-	m
5 Kedalaman gerusan di sekitar kepala jembatan	:	-	m
6 Kedalaman gerusan di sekitar tanah timbunan atau bangunan pengaman lainnya	:	-	m
7 Tinggi bebas perlintasan <i>overpass</i> jalan	:	-	m
8 Tinggi bebas perlintasan kereta api	:	-	m
9 Tinggi bagian tertinggi dari kapal laut dan/atau angkutannya terhadap elevasi terbawah bangunan atas jembatan	:	-	m
10 Lebar alur pelayaran untuk dibandingkan dengan kapal laut	:	-	m
11 Tinggi pylon dengan batasan lintasan pesawat udara dekat bandara	:	-	m



PEMERINTAH KOTA SEMARANG
DINAS PEKERJAAN UMUM

JL. MADUKORO RAYA NO. 7, TELP. (024) 76433969, FAX. (024) 76433969 KOTA SEMARANG

NO. JEMBATAN :

KT	3	3	0	7	4	0	6	0	0	6	7	0	0	1
----	---	---	---	---	---	---	---	---	---	---	---	---	---	---

NAMA JEMBATAN : SENDANGGUWO BARU 1

POTONGAN MEMANJANG

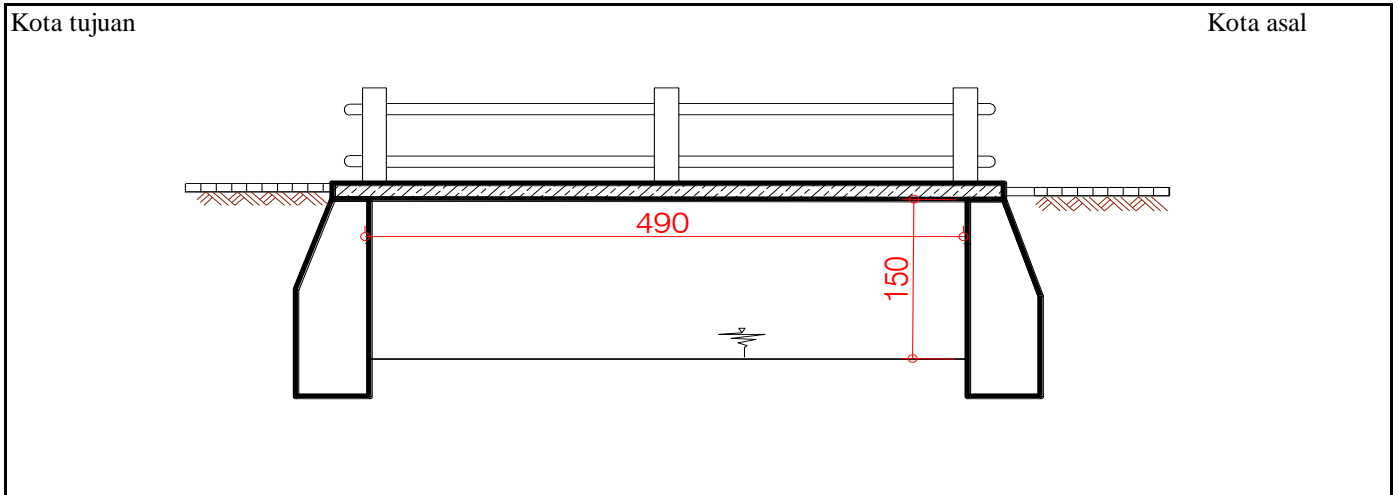

TAMPAK ATAS

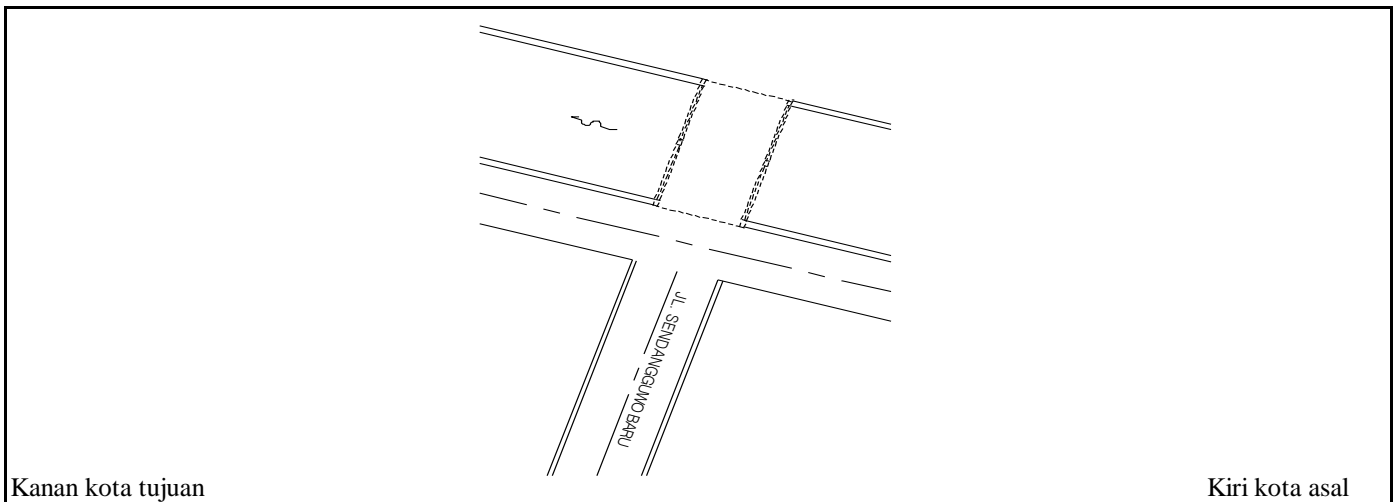

SITUASI

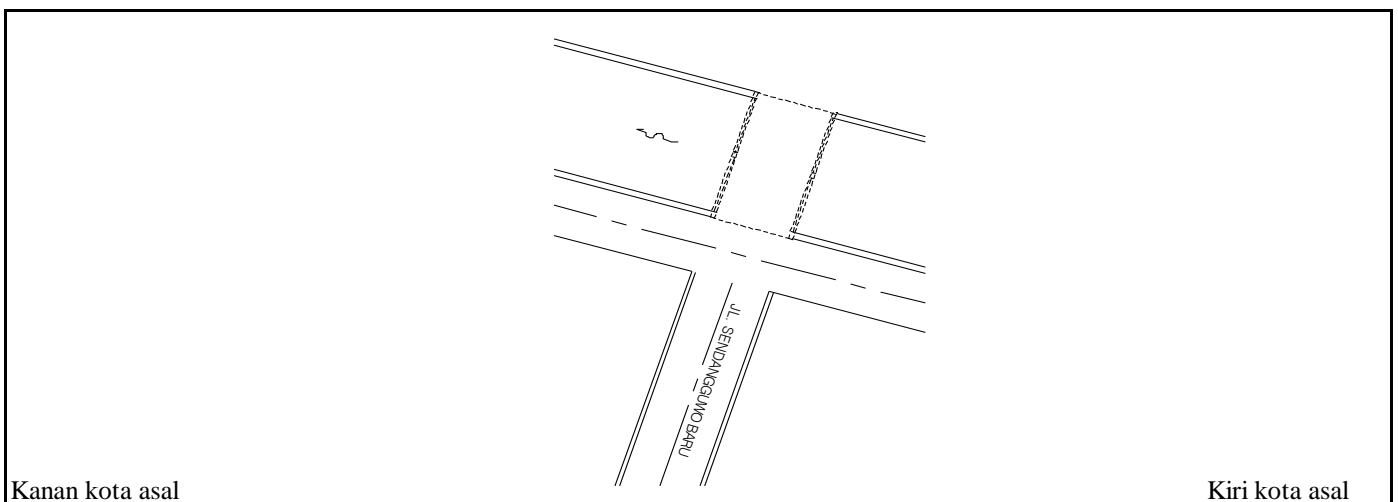



PEMERINTAH KOTA SEMARANG
DINAS PEKERJAAN UMUM

JL. MADUKORO RAYA NO. 7, TELP. (024) 76433969, FAX. (024) 76433969 KOTA SEMARANG



TAMPAK MEMANJANG



TAMPAK MEMANJANG



TAMPAK MELINTANG



TAMPAK MELINTANG

NOMOR JEMBATAN	NAMA JEMBATAN	LOKASI (Km)	PANJANG (M)
KT.33.074.06.0067.001	SENDANGGUWO BARU 1	0+000	4,10



PEMERINTAH KOTA SEMARANG
DINAS PEKERJAAN UMUM

JL. MADUKORO RAYA NO. 7, TELP. (024) 76433969, FAX. (024) 76433969 KOTA SEMARANG



KONDISI BANGUNAN BAWAH



TIANG SANDARAN PECAH



KONDISI ALIRAN SUNGAI



KONDISI LANTAI

NOMOR JEMBATAN	NAMA JEMBATAN	LOKASI (Km)	PANJANG (M)
KT.33.074.06.0067.001	SENDANGGUWO BARU 1	0+000	4,10



**PEMERINTAH KOTA SEMARANG
DINAS PEKERJAAN UMUM**

JL. MADUKORO RAYA NO. 7, TELP. (024) 76433969, FAX. (024) 76433969 KOTA SEMARANG

**FORM DETAIL JEMBATAN
Ruas Jalan
SENDANGGUWO BARU**

NO JEMBATAN : KT.33.074.06.0067.001
NAMA JEMBATAN : SENDANGGUWO BARU 1
TAHUN ANGGARAN : 2024



LAPORAN PEMERIKSAAN DETAIL JEMBATAN

No. Jembatan Ruas Jalan Kabupaten dan Kota

KT	3	3	0	7	4	0	6	0	0	6	7	0	0	1
----	---	---	---	---	---	---	---	---	---	---	---	---	---	---

Nama Jembatan	SENDANGGUWO BARU 1				Propinsi / Kabupaten / Kota Semarang	
Lokasi Jembatan	Koordinat Awal :	-7,00793	LS	110,46143	BT	Dari (Kota Asal/Km.No) : SMG
	Koordinat Akhir :	-7,00793	LS	110,46143	BT	Km. (Jarak dari kota asal) : 0+000
Tanggal Pemeriksaan 03/09/2024	Nama Pemeriksa / NIP GENDUT SUMANTO				Tahun Pembangunan	
Nilai Traffic :	0,072955	LHR :	307	Tahun :		2019

USULAN PEMERIKSAAN KHUSUS

Apakah tindakan darurat disarankan ?	Ya	Tidak
--------------------------------------	----	-------

Elemen elemen yang memerlukan Pemeriksaan Khusus

Kode	Elemen Uraian	Lokasi				Alasan untuk melakukan pemeriksaan khusus
		A/P/B	X	Y	Z	

TINDAKAN DARURAT

Apakah tindakan darurat disarankan ?	Ya	Tidak
--------------------------------------	----	-------

Elemen elemen yang memerlukan Tindakan Darurat

Kode	Elemen Uraian	Lokasi				Alasan untuk melakukan pemeriksaan khusus
		A/P/B	X	Y	Z	

Hanya untuk keperluan kantor

Tanggal memasukkan Data Pemeriksaan Inventarisasi 14/3/2024	Oleh : WAHYU DWIS
----------------------------------------------------------------	----------------------

Elemen		Elemen		Elemen		Kerusakan		Lokasi		Level 5					Level 4									
Kode	Uraian Level 2 (pilihan)	Kode	Uraian Level 3 (pilihan)	Kode	Uraian (pilihan)	Kode	Uraian (pilihan)			Nilai Kondisi					Nilai Kondisi									
								A/P/B	X	Y	Z	S	R	K	F	P	NK	S	R	K	F	P	NK	
				4.442	Pengaku Balok Pelengkung																			
				4.443	Sambungan Balok Pelengkung																			
				4.444	Balok Pelengkung Rangka Baja																			
				4.445	Penggantung Rangka Baja																			
				4.446	Perkuatan Balok Pelengkung																			
				4.447	Drainase Balok Pelengkung																			
		3.450	Rangka	4.451	Rangka Jembatan Panel																			
				4.451	Rangka Jembatan Panel																			
				4.452	Sambungan Rangka Jembatan Panel																			
				4.453	Struktur Rangka																			
				4.454	Pengaku Rangka																			
				4.455	Sambungan Rangka Baja																			
				4.456	Perkuatan Jembatan Rangka																			
				4.457	Drainase Rangka																			
		3.460	Jembatan - Beruji - Kabel (Cable-stayed)	4.461	Sistem Kabel Jembatan-Beruji-Kabel																			
				4.462	Sistem Penahan Kabel Jembatan-beruji-kabel																			
				4.463	Gelagar Melintang Jembatan Beruji Kabel (Cable stayed)																			
				4.464	Perkuatan Jembatan Beruji Kabel (Cable stayed)																			
		3.470	Jembatan Gantung	4.471	Sistem Kabel Jembatan Gantung																			
				4.472	Batang Penggantungan Jembatan Gantung																			
				4.473	Pengaku Jembatan Gantung																			
				4.474	Sistem penahan Kabel Jembatan Gantung																			
				4.475	Perkuatan Jembatan Gantung																			
				4.486	sadel pylon																			
				4.487	balok melintang																			
				4.488	ikatan angin bawah																			
				4.489	gantung/ sambungan																			
		3.480	Pilon	4.481	Struktur Pilon																			
				4.482	Penahan Kabel di Pilon																			
				4.483	Pilon Baja																			
				4.484	Sambungan Pilon Baja																			
				4.485	Perkuatan Pilon																			
				4.486	Drainase pilon																			
		3.490	Gelagar Boks	4.491	Struktur Gelagar Boks																			
				4.492	Pengaku gelagar boks																			
				4.493	Sambungan Gelagar Boks																			
				4.494	Prategang Eksternal dalam gelagar boks																			
				4.495	Perkuatan gelagar boks																			
				4.496	Drainase Gelagar Boks																			
		3.500	Sistem Lantai	4.511	Struktur Lantai																			
				4.512	Penyangga Sistem Lantai																			
				4.513	Trotoar dan kerb																			
				4.514	Lapis Permukaan Sistem Lantai																			
				4.515	Perkuatan Sistem Lantai																			
				4.516	Link Slab																			
				4.517	Drainase Lantai																			
		3.600	Sambungan/Siar Muai	4.601	Sambungan/Siar Muai Baja (tipe gergaji)																			
				4.602	Sambungan/Siar Muai Baja Siku Profil Terbuka																			
		3.610	Landasan/Perletakan	4.611	Landasan																			
				4.612	Peredam Pasif/Damping Struktur																			
				4.613	Peredam Aktif Struktur																			
				4.614	Pendukung landasan																			
				4.615	Penahan pergerakan landasan																			
				4.616	Ikatan / Perletakan lainnya																			
		3.620	Pengaman Pengguna Jalan	4.621	Struktur Sandaran Railling							0	1	0	0	0	1	0	1	0	0	0	0	1
				4.622	Struktur tembok																			
				4.623	Pembatas lainnya																			
		3.630	Perlengkapan Aerodinamik Jembatan	4.631	Perlengkapan Aerodinamik Bangunan Atas																			
				4.632	Perlengkapan Aerodinamik Permukaan Kabel Jembatan																			
				4.633	Wind Barrier																			
2.700	Perlengkapan	3.710	Perlengkapan Umum	4.711	Perangkat Pengendali Lalu Lintas																			
				4.712	Penanda Jembatan																			
				4.713	Penunjang Perlengkapan																			

LEVEL 3		Nilai Kondisi				
Kode	Elemen	S	R	K	F	NK
1.000	Jembatan	0	1	0	0	1

Elemen		Elemen		Elemen		Kerusakan		Lokasi		Level 5					Level 4																					
Kode	Uraian Level 2 (pilihan)	Kode	Uraian Level 3 (pilihan)	Kode	Uraian (pilihan)	Kode	Uraian (pilihan)	Nilai Kondisi					Nilai Kondisi																							
								A/P/B	X	Y	Z	S	R	K	F	P	NK	S	R	K	F	P	NK													
				4.714	Struktur Penutup Jembatan																															
				4.715	Pendukung sandaran / median																															
				4.721	Sistem penerangan																															
				4.721	Sistem penerangan																															
				4.722	Struktur Tiang Pengaman																															
				4.723	Penunjang Penerangan																															
				4.731	Utilitas Kabel Listrik																															
				4.732	Utilitas Pipa Air Minum																															
				4.733	Utilitas Kabel Telekomunikasi																															
				7.734	Utilitas Pipa Air Kotor																															
				4.735	Utilitas Pipa Pembawa Bahan Energi lainnya																															
				7.736	Sambungan utilitas																															
				4.737	Dudukan utilitas																															
				4.741	Perangkat Pengendali Kelembaban																															
				4.742	Perangkat Penangkal Petir																															
				4.743	Perangkat Perlindungan Korosi dan Biota Laut																															
				4.744	Lubang Ventilasi																															
				4.745	Penutup Lubang Ventilasi																															
				4.751	Sensor Struktur																															
				4.752	Perangkat Pengukur Beban Kendaraan																															
				4.753	Sensor pengukur Beban Kendaraan																															
				4.754	Pendukung lainnya																															
				4.755	Perangkat Penukar Data																															
				4.761	Sistem penggerak fungsional																															
				4.762	Sistem Elektrik																															
				4.763	Sistem Hidrolik																															
				4.764	Sistem Mekanis																															
				4.771	Tangga / Platform Pemeriksaan																															
				4.772	Lubang Masuk (gelagar, kolom)																															
				4.773	Traveler																															
				2.800	gorong - gorong	3.810	Tanah di dalam struktur Gorong - gorong	4.811	Tanah timbunan di atas gorong - gorong																											
								4.812	Tanah dasar di bawah struktur gorong - gorong																											
								3.820	Gorong - gorong Persegi Boks	4.821	Dinding Tegak																									
										4.822	Pelat Bawah																									
										4.823	Pelat Atas																									
										4.824	Drainase Gorong - gorong Persegi Boks																									
								3.830	Gorong - gorong Pipa	4.831	Dinding penahan tanah timbunan																									
										4.832	Drainase Gorong - gorong Pipa																									
								Gorong - gorong Pelengkung Baja Gelombang	4.841	Pelat Baja Gelombang																										
									4.842	Sambungan / Baut pengikat																										
									4.843	Fondasi / Pelat Beton Dudukan Pelengkung Baja Gelombang																										
									4.844	Drainase Gorong gorong Pelengkung Baja Bergelombang																										
								3.850	Struktur Pendukung Gorong - gorong	4.851	Tembok Savap																									
										4.852	Tembok Kepala (Head wall) Gorong-gorong																									
										4.853	Tembok Bawah (Drop wall) Gorong-gorong																									
										4.854	Apron																									
								3.860	Perkuatan Gorong - gorong	4.861	Perkuatan dengan Lapisan Beton Tambahan																									
4.862	Perkuatan dengan FRP																																			
4.863	Perkuatan dengan Lapisan Baja Tambahan																																			
2.900	Struktur Lintasan B	3.910	Lintasan dengan Perkerasan																																	
		3.920	Lintasan Alam (tanpa perkerasan)																																	
		3.930	Lintasan dengan struktur semi - permanen																																	

LEVEL 3		Nilai Kondisi					
Kode	Elemen	S	R	K	F	P	NK



**PEMERINTAH KOTA SEMARANG
DINAS PEKERJAAN UMUM**

JL. MADUKORO RAYA NO. 7, TELP. (024) 76433969, FAX. (024) 76433969 KOTA SEMARANG

NO. JEMBATAN

:	KT	3	3	0	7	4	0	6	0	0	6	7	0	0	1
---	----	---	---	---	---	---	---	---	---	---	---	---	---	---	---

NAMA JEMBATAN

: SENDANGGUWO BARU 1

POTONGAN MEMANJANG

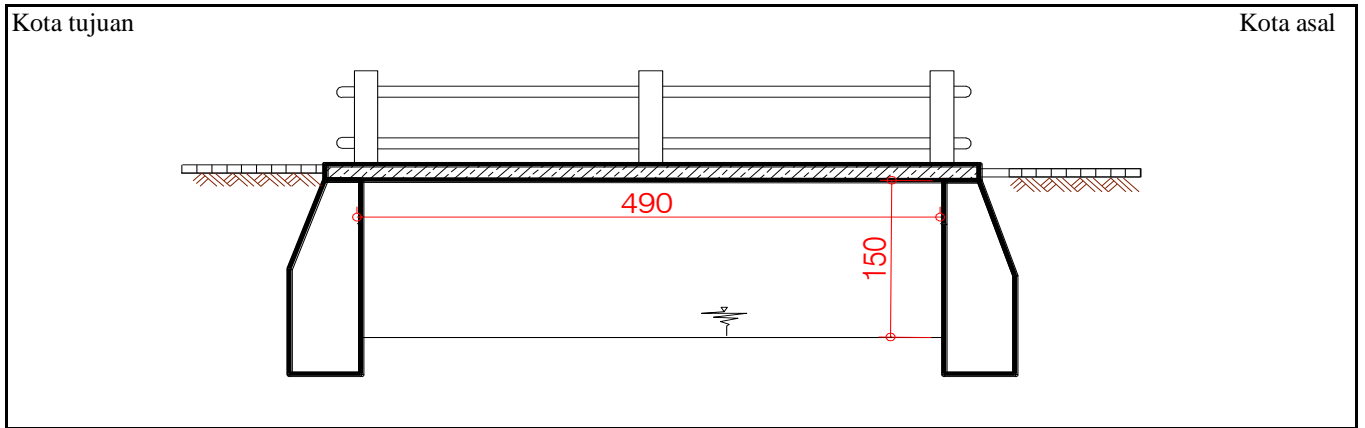

TAMPAK ATAS

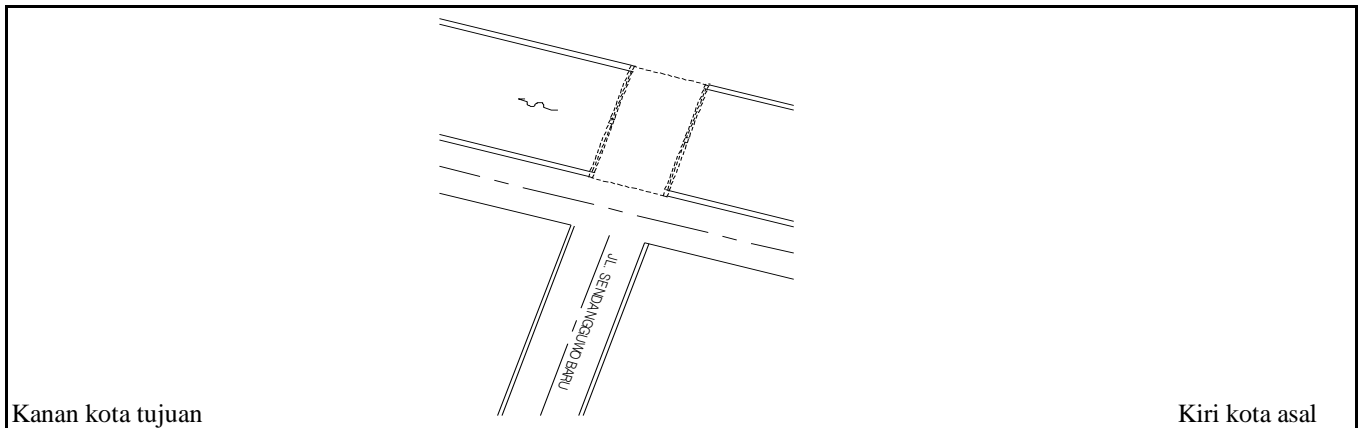

SITUASI

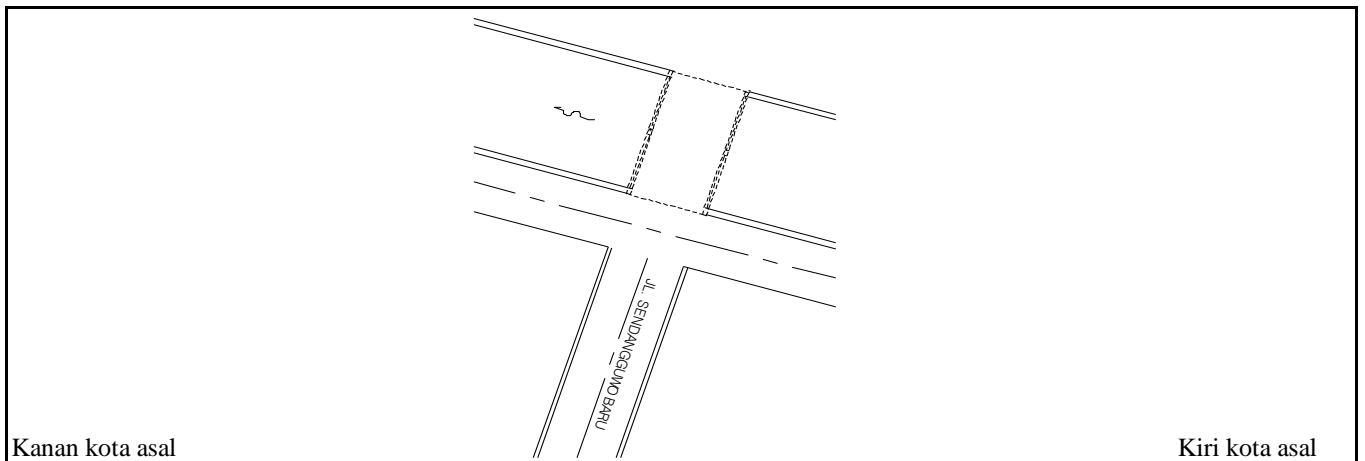



**PEMERINTAH KOTA SEMARANG
DINAS PEKERJAAN UMUM**

JL. MADUKORO RAYA NO. 7, TELP. (024) 76433969, FAX. (024) 76433969 KOTA SEMARANG



TAMPAK MEMANJANG



TAMPAK MEMANJANG



TAMPAK MELINTANG



TAMPAK MELINTANG

NOMOR JEMBATAN	NAMA JEMBATAN	LOKASI (Km)	PANJANG (M)
KT.33.074.06.0067.001	SENDANGGUWO BARU 1	0+000	4,10



PEMERINTAH KOTA SEMARANG
DINAS PEKERJAAN UMUM

JL. MADUKORO RAYA NO. 7, TELP. (024) 76433969, FAX. (024) 76433969 KOTA SEMARANG



KONDISI BANGUNAN BAWAH



TIANG SANDARAN PECAH



KONDISI ALIRAN SUNGAI



KONDISI LANTAI

NOMOR JEMBATAN	NAMA JEMBATAN	LOKASI (Km)	PANJANG (M)
KT.33.074.06.0067.001	SENDANGGUWO BARU 1	0+000	4,10