



**PEMERINTAH KOTA SEMARANG  
DINAS PEKERJAAN UMUM**

JL. MADUKORO RAYA NO. 7, TELP. (024) 76433969, FAX. (024) 76433969 KOTA SEMARANG

---

**FORM INVENTARISASI JEMBATAN  
Ruas Jalan  
NGILIR TIMUR V**

**NO JEMBATAN : KT.33.074.05.1007.054.001**  
**NAMA JEMBATAN : KALI SRINGIN**  
**TAHUN ANGGARAN : 2024**



## LAPORAN PEMERIKSAAN INVENTARISASI JEMBATAN

No. Jembatan Ruas Jalan Kabupaten dan Kota

KT	3	3	0	7	4	0	5	1	0	0	7	0	5	4	0	0	1
----	---	---	---	---	---	---	---	---	---	---	---	---	---	---	---	---	---

Nama Jembatan	<b>KALI SRINGIN</b>				Propinsi / Kabupaten / Kota Semarang				
Lokasi Jembatan	Koordinat Awal : Koordinat Akhir :	-6,9532850 -6,9532850	LS LS	110,4719760 110,4719760	BT BT	Dari (Kota Asal/Km.No) :	SMG	Km. (Jarak dari kota asal) :	0+150
Tanggal Pemeriksaan 08/03/2024	Nama Pemeriksa / NIP GENDUT SUMANTO				Tahun Pembangunan -				
Nilai Lalu - Lintas :	-				LHR : -		Tahun : -		

### INFORMASI PEMBANGUNAN JEMBATAN

1 Tanggal / Bulan / Tahun pembangunan jembatan / pengoperasian pertama kali	:	-	
2 Tanggal / Bulan / Tahun pelebaran/rehabilitasi/perkuatan jembatan / pengoperasian pertama kali	:	-	
3 Tanggal / Bulan / Tahun serah terima aset	:	-	
4 Penanggung jawab pembangunan (Satker/PPK)	:	-	
5 Penanggung jawab pelebaran/rehabilitasi/perkuatan jembatan (Satker/PPK)	:	-	
6 Biaya perencanaan	:	-	
7 Biaya pembangunan	:	-	
8 Biaya pelebaran/rehabilitasi/perkuatan jembatan	:	-	
9 Biaya pengujian	:	-	
10 Nilai aset serah terima	:	-	
11 Nama konsultan perencana pembangunan	:	-	
12 Nama <i>Independent Proof Checker</i> (IPC)	:	-	
13 Nama konsultan perencana pelebaran/rehabilitasi/perkuatan jembatan	:	-	
14 Nama kontraktor pelaksana pembangunan	:	-	
15 Nama kontraktor pelaksana pelebaran/rehabilitasi/perkuatan jembatan	:	-	
16 Nama subkontraktor spesialis	:	-	
17 Nama konsultan pengawas pembangunan	:	-	
18 Nama konsultan pengawas pelebaran/rehabilitasi/perkuatan jembatan	:	-	
19 Nama konsultan pengujian	:	-	
		Tersedia / Tidak	File
20 Laporan pembangunan/pelebaran/rehabilitasi/perkuatan jembatan	:	TIDAK	
21 <i>As-built-drawing</i> atau denah jembatan	:	TIDAK	

Hanya untuk keperluan kantor

Tanggal memasukkan Data Pemeriksaan Inventarisasi 22/03/2024	Oleh : WAHYU DWIS
---	----------------------



**PEMERINTAH KOTA SEMARANG**  
**DINAS PEKERJAAN UMUM**

JL. MADUKORO RAYA NO. 7, TELP. (024) 76433969, FAX. (024) 76433969 KOTA SEMARANG

**INFORMASI KAPASITAS MUATAN**

1 Batasan muatan sumbu terberat MST	: -	ton
2 Beban maksimum yang pernah di atas jembatan	: 0,5	ton
3 Jenis kendaraan berat yang umum lewat di atas jembatan	: SEPEDA MOTOR	
4 Tindakan darurat yang sedang/pernah dilakukan di atas jembatan	: E	
a. Pembatasan beban		
b. Penyokongan/Sangga		
c. Penutupan parsial/Sebagian		
d. Penutupan penuh		
e. Jalan Memutar/ <i>detour</i>		
f. Jembatan Sementara		
5 Apakah tersedia jalan memutar/ <i>detour</i> jika jembatan ditutup	<b>Ya</b>	tidak
6 Panjang jarak tambahan yang harus ditempuh dengan jalan memutar	300	m

**INFORMASI KAPASITAS LALU LINTAS**

1 Lalu - lintas harian rata-rata tahunan (LHR) AADT	: -	
2 Nilai Lalu - Lintas (Perbandingan lebar jalur lalu-lintas yang tersedia di atas jembatan dengan lebar perkerasan sebelum masuk ke dalam jembatan)		
Longgar kendaraan bebas melintas di atas jembatan	0	
Cukup lebar kendaraan melaju perlahan di atas jembatan	3	
Sempit kendaraan harus antri atau berhenti	<b>5</b>	
3 Lebar kendaraan maksimum ( <i>ODOL/Over-dimension overload vehicle</i> )	: 0,5	m

**INFORMASI BATASAN PERLINTASAN DAN LINGKUNGAN**

1 Tinggi muka air banjir terhadap bagian atas lantai jembatan	: 1	m
2 Tinggi muka air banjir terhadap elevasi perletakan jembatan	: -	m
3 Tinggi muka air banjir terhadap elevasi terbawah bangunan atas jembatan	: 0,5	m
4 Kedalaman gerusan di sekitar pilar	: -	m
5 Kedalaman gerusan di sekitar kepala jembatan	: -	m
6 Kedalaman gerusan di sekitar tanah timbunan atau bangunan pengaman lainnya	: -	m
7 Tinggi bebas perlintasan <i>overpass</i> jalan	: -	m
8 Tinggi bebas perlintasan kereta api	: -	m
9 Tinggi bagian tertinggi dari kapal laut dan/atau angkutannya terhadap elevasi terbawah bangunan atas jembatan	: -	m
10 Lebar alur pelayaran untuk dibandingkan dengan kapal laut	: -	m
11 Tinggi pilon dengan batasan lintasan pesawat udara dekat bandara	: -	m



**PEMERINTAH KOTA SEMARANG**  
**DINAS PEKERJAAN UMUM**

JL. MADUKORO RAYA NO. 7, TELP. (024) 76433969, FAX. (024) 76433969 KOTA SEMARANG

**KODE-KODE PEMERIKSAAN INVENTARISASI JEMBATAN**

Tipe Lintasan		JN (jalan)	SL (sungai lurus)	SM (sungai meander)	SB (sungai berjalir)	S/T (selat atau teluk)	KA (Kereta Api)	L (lain-lain)						
<b>A. TBA (Tipe Bangunan Atas)</b>		<b>B. BHN (Bahan)</b>			<b>C1. SBA (Sifat Bangunan Atas)</b>		<b>C2. Keterangan Detail</b>		<b>D. TF (Tipe Fondasi)</b>		<b>E. KJP (Kepala Jembatan/Pilar)</b>			
B	gorong-gorong persegi	K	Kayu	P	Permanen	A	Australia	CA	Cakar Ayam	A	Cap (Kepala tiang)			
Y	gorong-gorong pipa	S	Pasangan bata	S	Semi Permanen	T	Australia (Sementara)	LS	Langsung		B	Dinding penuh		
A	gorong-gorong pelengkung	M	Pasangan batu	W	Darurat	B	Belanda (tipe baru)	TP	Tiang Pancang	K	Kepala jembatan khusus			
T	gantung	G	Bronjong dan sejenisnya	X	Tidak ada struktur	D	Belanda (tipe lama)	PB	Tiang Bor	<b>Pilar</b>				
C	Jembatan Gantungan / Beruji Kabel (Cable Stayed)	H	Pasangan batu kosong	M	Bergerak	I	Indonesia	TU	Tiang Ulir					
G	gelagar	D	Beton tak bertulang	F	Apung	J	Jepang	SU	Sumuran	<b>PILON</b>				
M	gelagar komposit	T	Beton bertulang			R	Austria	LL	Lain-lain					
O	Gelagar Boks	P	Beton pratekan			E	Spanyol	<b>PILON</b>		C	Cap (kepala tiang)			
Q	Gelagar tipe U	B	Baja			U	Callender Hamilton (UK/Inggris)			A	Tipe A	P	Dinding penuh	
L	balok pelengkung	U	Pelat baja gelombang			W	Acrow/Bailey	D	Tipe Diamond	S	Satu kolom			
E	pelengkung	Y	Komposit Baja - beton			<b>Catatan :</b> <i>Asal produksi jembatan, apabila diketahui pasti, dari pemeriksaan detail dapat dituliskan atau diganti dengan sifat apabila tidak pasti</i>		H	Tipe H	D	Dua kolom			
D	Flat Slab	J	Alumunium					I	Tipe Tunggal / I	T	Tipe Y	T	Tiga atau lebih kolom	
V	Voided Slab	E	Neoprene / karet					V	Tipe V terbuka	L	Tipe V	L	Lain-lain	
R	rangka	F	Teflon					W	Tipe Double I	V	Tipe V	V	Tipe V	
P	Pelat	V	PVC					<b>Tiang Sandaran</b>				TB	tiang beton sandaran baja	
F	ferry	N	geotextile									BB	tiang baja sandaran baja	
K	lintasan kereta api	O	Tanah biasa/lempung atau timbunan									DB	dinding bagian bawah + sandaran baja	
W	lintasan basah	A	Aspal									DD	Sandaran/Median beton bertulang	
U	lain-lain	R	kerikil/pasir									KK	tiang kayu sandaran kayu	
		W	Macadam											







**PEMERINTAH KOTA SEMARANG**  
**DINAS PEKERJAAN UMUM**

JL. MADUKORO RAYA NO. 7, TELP. (024) 76433969, FAX. (024) 76433969 KOTA SEMARANG

**NO. JEMBATAN** : 

KT	3	3	0	7	4	0	5	1	0	0	7	0	5	4	0	0	1
----	---	---	---	---	---	---	---	---	---	---	---	---	---	---	---	---	---

**NAMA JEMBATAN** : KALI SRINGIN.....

**POTONGAN MEMANJANG**

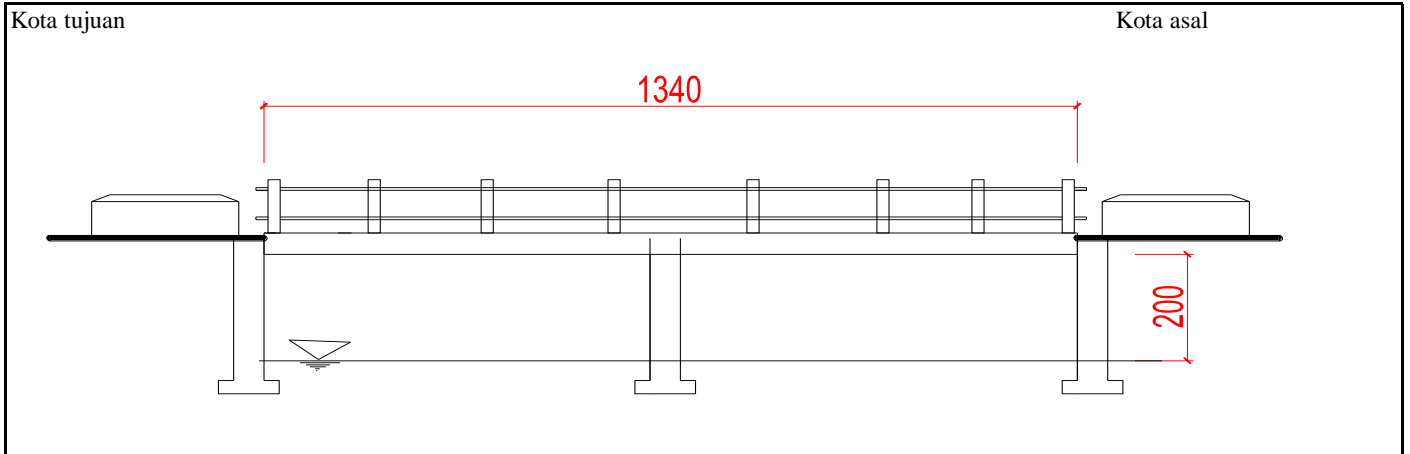

**TAMPAK ATAS**

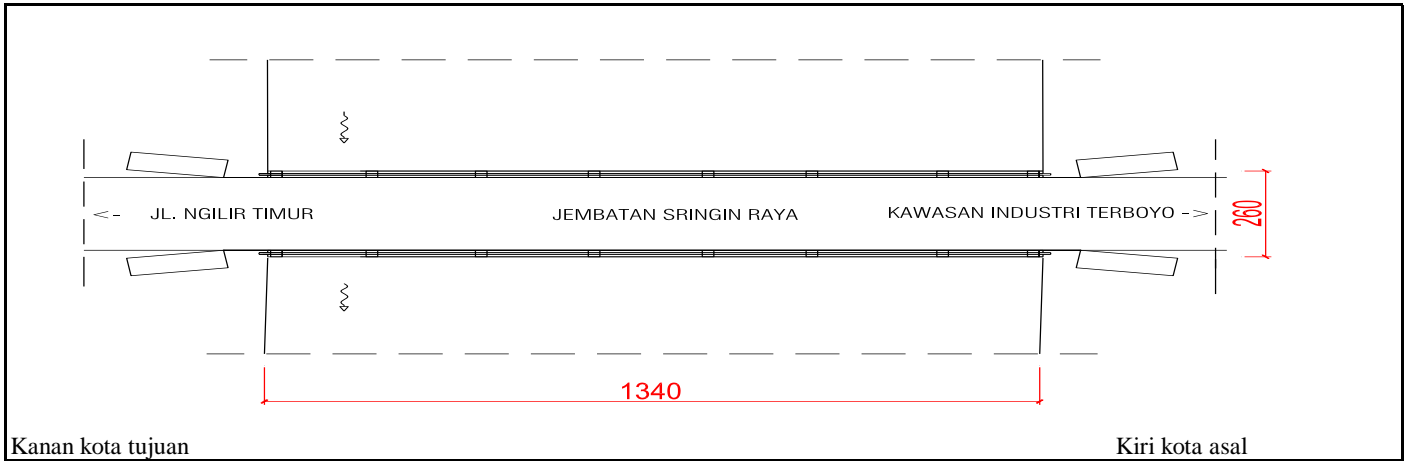

**SITUASI**

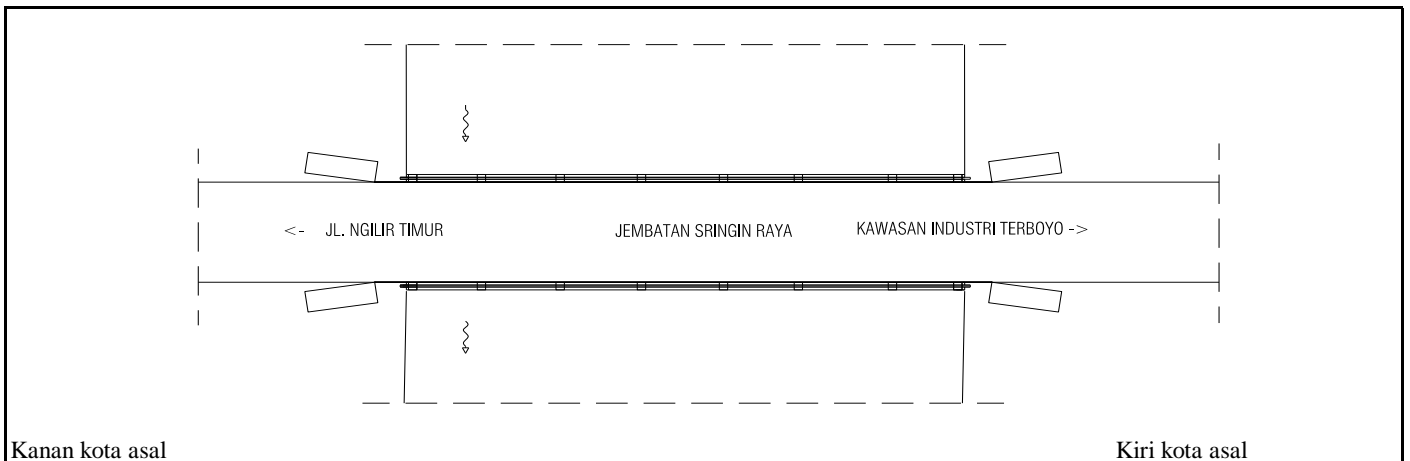



**TAMPAK MEMANJANG**



**TAMPAK MEMANJANG**



**TAMPAK MELINTANG**



**TAMPAK MELINTANG**

<b>NOMOR JEMBATAN</b>	<b>NAMA JEMBATAN</b>	<b>LOKASI (Km)</b>	<b>PANJANG (M)</b>
KT.33.074.05.1007.054.001	KALI SRINGIN	0+150	13,40





**PEMERINTAH KOTA SEMARANG**  
**DINAS PEKERJAAN UMUM**

JL. MADUKORO RAYA NO. 7, TELP. (024) 76433969, FAX. (024) 76433969 KOTA SEMARANG



**JALAN PENDEKAT BERLUBANG**



**LANTAI JEMBATAN PECAH**



**PARAPET PECAH**



**JEMBATAN RUNTUH**

<b>NOMOR JEMBATAN</b>	<b>NAMA JEMBATAN</b>	<b>LOKASI (Km)</b>	<b>PANJANG (M)</b>
KT.33.074.05.1007.054.001	KALI SRINGIN	0+150	13,40



**PEMERINTAH KOTA SEMARANG  
DINAS PEKERJAAN UMUM**

JL. MADUKORO RAYA NO. 7, TELP. (024) 76433969, FAX. (024) 76433969 KOTA SEMARANG

---

**FORM DETAIL JEMBATAN  
Ruas Jalan  
NGILIR TIMUR V**

**NO JEMBATAN : KT.33.074.05.1007.054.001**  
**NAMA JEMBATAN : KALI SRINGIN**  
**TAHUN ANGGARAN : 2024**



## LAPORAN PEMERIKSAAN DETAIL JEMBATAN

No. Jembatan Ruas Jalan Kabupaten dan Kota

KT	3	3	0	7	4	0	5	1	0	0	7	0	5	4	0	0	1
----	---	---	---	---	---	---	---	---	---	---	---	---	---	---	---	---	---

Nama Jembatan	KALI SRINGIN				Propinsi / Kabupaten / Kota Semarang				
Lokasi Jembatan	Koordinat Awal :	-6,953285	LS	110,471976	BT	Dari (Kota Asal/Km.No1) :	SMG		
	Koordinat Akhir :	-6,953285	LS	110,471976	BT	Km. (Jarak dari kota asal) :	0+150		
Tanggal Pemeriksaan 08 March 2024	Nama Pemeriksa / NIP GENDUT SUMANTO				Tahun Pembangunan				
Nilai Traffic :	-	LHR :	-	-	-	Tahun :	-		

### USULAN PEMERIKSAAN KHUSUS

Apakah tindakan darurat disarankan ? Ya  Tidak

#### Elemen elemen yang memerlukan Pemeriksaan Khusus

Kode	Elemen Uraian	Lokasi				Alasan untuk melakukan pemeriksaan khusus
		A/P/B	X	Y	Z	

### TINDAKAN DARURAT

Apakah tindakan darurat disarankan ? Ya  Tidak

#### Elemen elemen yang memerlukan Tindakan Darurat

Kode	Elemen Uraian	Lokasi				Alasan untuk melakukan pemeriksaan khusus
		A/P/B	X	Y	Z	
1.000	Jembatan					Runtuh

#### Hanya untuk keperluan kantor

Tanggal memasukkan Data Pemeriksaan Inventarisasi : 22 March 2024  
Oleh : WAHYU DWIS



LAPORAN PEMERIKSAAN MENDETAIL JEMBATAN

DAFTAR KERUSAKAN UNTUK LEVEL 3-5

No. Jembatan	KT	3	3	0	7	4	0	5	1	0	0	7	0	5	4	0	0	1
--------------	----	---	---	---	---	---	---	---	---	---	---	---	---	---	---	---	---	---

EVALUASI ELEMEN

Elemen Kode	Uraian Level 2 (pilihan)	Elemen Kode	Uraian Level 3 (pilihan)	Elemen Kode	Uraian (pilihan)	Kerusakan Kode	Uraian (pilihan)	Lokasi		Level 5					Level 4										
								A/P/B	X	Y	Z	Nilai Kondisi					Nilai Kondisi								
												S	R	K	F	P	NK	S	R	K	F	P	NK		
2.100	Jalan Pendekat	3.110	Perkerasan Jalan Pendekat	4.111	Perkerasan Fleksibel Jalan Pendekat																				
				4.112	Perkerasan Kaku Jalan Pendekat	722	Permukaan yang kasar/berlubang (debonding, aus) atau retak				1	1	1	0	0	3	1	1	1	0	0	3			
				4.113	Pelat Injak																				
				4.114	Sleeper Slab																				
				4.115	Drainase Perkerasan																				
		3.120	Tanah Timbunan	4.121	Tanah Timbunan																				
				4.122	Timbunan Ringan																				
				4.123	Geosintetik																				
				4.124	Drainase Tanah Timbunan																				
		3.130	Struktur Penahan Tanah Jalan Pendekat	4.131	Dinding Penahan Tanah																				
				4.132	Tanah Bertulang/Mechanically Stabilized Earth (MSE)																				
				4.133	Drainase Struktur Penahan Tanah																				
				4.134	Soil nailing																				
		3.140	Pengaman lalu - lintas	4.141	Tiang Pengaman Jalan Pendekat																				
4.142	Pagar Pengaman/Guardrail Jalan Pendekat																								
2.200	Aliran Sungai	3.210	Aliran Sungai	4.211	tebing sungai	503	Pengikisan di sepanjang aliran sungai (contraction scour)					1	1	0	0	1	3	1	1	0	0	1	3		
				4.212	aliran air utama	501	Pendangkalan sungai akibat endapan (agradasi)				1	1	1	0	1	4	1	1	1	0	1	4			
				4.213	daerah genangan banjir																				
		3.220	Bangunan Pengaman	4.221	Pengaman Aliran Sungai																				
				4.222	Pengaman Tebing Sungai	503	Pengikisan di sepanjang aliran sungai (contraction scour)				1	1	0	0	1	3	1	1	0	0	1	3			
4.223	Pengaman Bangunan Bawah																								
4.224	Perkuatan bangunan Pengaman																								
2.300	Bangunan Bawah	3.310	Pondasi	4.311	Fondasi Tiang																				
				4.312	Fondasi Sumuran																				
				4.313	Fondasi Langsung	521	Pengikisan di sekitar jembatan (local scour)				1	1	1	1	1	5	1	1	1	1	1	5			
				4.314	Pondasi Balok Pelengkung																				
				4.315	Sambungan Fondasi dan Lainnya																				
				4.316	Perkuatan Fondasi																				
				4.317	Struktur jembatan apung																				
		3.320	Kepala Jembatan/Pilar	4.321	Balok Fondasi																				
				4.322	Dinding kepala jembatan / pilar	205	Pecah atau hilangnya bahan (delaminasi, abrasi, aus)				1	1	1	1	1	5	1	1	1	1	1	5			
				4.323	Balok Kepala Jembatan/Pilar																				
				4.324	Struktur pengaku																				
4.325	Sambungan kepala jembatan / pilar																								
4.326	Perkuatan bangunan bawah																								
4.327	Drainase Kepala jembatan / pilar																								
2.400	Bangunan Atas	3.410	Sistem Gelagar	4.411	Gelagar utama																				
				4.412	Diafragma																				
				4.413	Pengaku gelagar baja																				
				4.414	Perkuatan gelagar																				
				4.415	Sambungan gelagar																				
				4.416	Drainase Gelagar																				

LEVEL 3		Nilai Kondisi					
Kode	Elemen	S	R	K	F	P	NK
3.110	Perkerasan Jalan Pendekat	1	1	1	0	0	3
3.120	Tanah Timbunan						-
3.130	Struktur Penahan Tanah Jalan Pendekat						-
3.140	Pengaman lalu-lintas						-
3.210	Aliran Sungai	1	1	1	0	1	4
3.220	Bangunan Pengaman	1	1	0	0	1	3
3.310	Fondasi	1	1	1	1	1	5
3.320	Kepala Jembatan/Pilar	1	1	1	1	1	5
3.410	Sistem Gelagar						-
3.420	Jembatan Pelat	1	1	1	1	1	5
3.430	Pelengkung						-
3.440	Balok Pelengkung						-
3.450	Rangka						-
3.460	Jembatan Beruji Kabel (Cable-Stayed)						-
3.470	Jembatan Gantung						-
3.480	Pilon						-
3.490	Gelagar Boks						-
3.500	Sistem Lantai	1	1	1	1	1	5
3.600	Sambungan / Siar muai						-
3.610	Perletakan						-
3.620	Pengaman Pengguna Jalan	1	1	1	1	1	5
3.630	Perlengkapan Aerodinamik Jembatan						-
3.710	Perlengkapan Umum						-
3.720	Penerangan						-
3.730	Utilitas						-
3.740	Pengaman struktur dan lingkungan						-
3.750	SMKS (Sistem Monitoring Kesehatan Jembatan)						-
3.760	Perlengkapan Jembatan Gerak/moveable bridge						-
3.770	Fasilitas Pemeriksaan Tetap						-
3.810	Tanah di dalam struktur Gorong-gorong						-
3.820	Gorong - gorong persegi Boks						-
3.830	Gorong- gorong pipa						-
3.840	Gorong - gorong Pelengkung Baja Gelombang						-
3.850	Struktur Pendukung Gorong-gorong						-
3.860	Perkuatan gorong - gorong						-
3.910	Lintasan dengan perkerasan						-
3.920	Lintasan alam (tanpa perkerasan)						-
3.930	Lintasan dengan struktur semi - permanen						-

LEVEL 2		Nilai Kondisi					
Kode	Elemen	S	R	K	F	P	NK

Elemen		Elemen		Elemen		Kerusakan		Lokasi		Level 5						Level 4											
Kode	Uraian Level 2 (pilihan)	Kode	Uraian Level 3 (pilihan)	Kode	Uraian (pilihan)	Kode	Uraian (pilihan)	A/P/B	X	Y	Z	S	R	K	F	P	NK	S	R	K	F	P	NK				
		3.420	Jembatan Pelat	4.421	pelat beton bertulang	701	Pergerakan yang berlebih arah memanjang sambungan					1	1	1	1	1	5	1	1	1	1	1	5				
				4.422	Pelat beton pracetak pratekan																						
				4.423	Kabel prategang melintang																						
				4.424	Shear key (sambungan antar pelat beton pracetak pratekan - flat slab. )																						
				4.425	Perkuatan Jembatan Pelat	701	Pergerakan yang berlebih arah memanjang sambungan								1	1	1	1	1	5	1	1	1	1	1	5	
		4.426	Drainase Jembatan Pelat																								
		3.430	Pelengkung	4.431	Pelengkung																						
				4.432	Dinding pelengkung																						
				4.433	Perkuatan pelengkung																						
				4.434	Drainase Pelengkung																						
		3.440	Balok Pelengkung	4.441	balok pelengkung																						
				4.442	Pengaku Balok Pelengkung																						
				4.443	Sambungan Balok Pelengkung																						
				4.444	Balok Pelengkung Rangka Baja																						
				4.445	Penggantung Rangka Baja																						
				4.446	Perkuatan Balok Pelengkung																						
				4.447	Drainase Balok Pelengkung																						
		3.450	Rangka	4.451	Rangka Jembatan Panel																						
				4.451	Rangka Jembatan Panel																						
				4.452	Sambungan Rangka Jembatan Panel																						
				4.453	Struktur Rangka																						
				4.454	Pengaku Rangka																						
				4.455	Sambungan Rangka Baja																						
				4.456	Perkuatan Jembatan Rangka																						
		4.457	Drainase Rangka																								
		3.460	Jembatan - Beruji - Kabel (Cable-stayed)	4.461	Sistem Kabel Jembatan-Beruji-Kabel																						
				4.462	Sistem Penahan Kabel Jembatan-beruji-kabel																						
				4.463	Gelagar Melintang Jembatan Beruji Kabel (Cable stayed)																						
				4.464	Perkuatan Jembatan Beruji Kabel (Cable stayed)																						
		3.470	Jembatan Gantung	4.471	Sistem Kabel Jembatan Gantung																						
				4.472	Batang Peggantung Jembatan Gantung																						
				4.473	Pengaku Jembatan Gantung																						
				4.474	Sistem penahan Kabel Jembatan Gantung																						
				4.475	Perkuatan Jembatan Gantung																						
				4.486	sadel pylon																						
				4.487	balok melintang																						
		3.480	Pilon	4.488	ikatan angin bawah gantung/ sambungan																						
				4.489																							
				4.481	Struktur Pilon																						
				4.482	Penahan Kabel di Pilon																						
				4.483	Pilon Baja																						
				4.484	Sambungan Pilon Baja																						
				4.485	Perkuatan Pilon																						
		3.490	Gelagar Boks	4.486	Drainase pilon																						
				4.491	Struktur Gelagar Boks																						
				4.492	Pengaku gelagar boks																						
				4.493	Sambungan Gelagar Boks																						
				4.494	Prategang Eksternal dalam gelagar boks																						
				4.495	Perkuatan gelagar boks																						
		3.500	Sistem Lantai	4.496	Drainase Gelagar Boks																						
4.511	Struktur Lantai			701	Pergerakan yang berlebih arah memanjang sambungan								1	1	1	1	1	5	1	1	1	1	1	5			
4.512	Penyangga Sistem Lantai																										
4.513	Trotoar dan kerb																										
4.514	Lapis Permukaan Sistem Lantai	701	Pergerakan yang berlebih arah memanjang sambungan									1	1	1	1	1	5	1	1	1	1	1	5				

LEVEL 3		Nilai Kondisi					
Kode	Elemen	S	R	K	F	P	NK
2.100	Jalan Pendekat	1	1	1	0	0	3
2.200	Aliran Sungai	1	1	1	0	1	4
2.300	Bangunan Bawah	1	1	1	1	1	5
2.400	Bangunan Atas	1	1	1	1	1	5
2.700	Perlengkapan						-
2.800	Gorong-gorong						-
2.900	Struktur Lintasan Basah						-

LEVEL 1		Nilai Kondisi					
Kode	Elemen	S	R	K	F	P	NK
1.000	Jembatan	1	1	1	1	1	5

Elemen		Elemen		Elemen		Kerusakan		Lokasi		Level 5					Level 4								
Kode	Uraian Level 2 (pilihan)	Kode	Uraian Level 3 (pilihan)	Kode	Uraian (pilihan)	Kode	Uraian (pilihan)	A/P/B	X	Y	Z	S	R	K	F	P	NK	S	R	K	F	P	NK
				4.515	Perkuatan Sistem Lantai	701	Pergerakan yang berlebih arah memanjang sambungan					1	1	1	1	1	5	1	1	1	1	1	5
				4.516	Link Slab																		
				4.517	Drainase Lantai																		
		3.600	Sambungan/Siar Muai	4.601	Sambungan/Siar Muai Baja (tipe gergaji)																		
				4.602	Sambungan/Siar Muai Baja Siku Profil Terbuka																		
		3.610	Landasan/Perletakan	4.611	Landasan																		
				4.612	Peredam Pasif/Damping Struktur																		
				4.613	Peredam Aktif Struktur																		
				4.614	Pendukung landasan																		
				4.615	Penahan pergerakan landasan																		
				4.616	Ikatan / Perletakan Lainnya																		
		3.620	Pengaman Pengguna Jalan	4.621	Struktur Sandaran Railling	305	Komponen yang rusak / hilang (sobek, abrasi)					1	1	1	1	1	5	1	1	1	1	1	5
				4.622	Struktur tembok	205	Pecah atau hilangnya bahan (delaminasi, abrasi, aus)					1	1	1	0	1	4	1	1	1	0	1	4
				4.623	Pembatas lainnya																		
		3.630	Perlengkapan Aerodinamik Jembatan	4.631	Perlengkapan Aerodinamik Bangunan Atas																		
				4.632	Perlengkapan Aerodinamik Permukaan Kabel Jembatan																		
				4.633	Wind Barrier																		
2.700	Perlengkapan	3.710	Perlengkapan Umum	4.711	Perangkat Pengendali Lalu Lintas																		
				4.712	Penanda Jembatan																		
				4.713	Penunjang Perlengkapan																		
				4.714	Struktur Penutup Jembatan																		
				4.715	Pendukung sandaran / median																		
				4.721	Sistem penerangan																		
		3.720	Penerangan	4.721	Sistem penerangan																		
				4.722	Struktur Tiang Pengaman																		
				4.723	Penunjang Penerangan																		
		3.730	Utilitas	4.731	Utilitas Kabel Listrik																		
				4.732	Utilitas Pipa Air Minum																		
				4.733	Utilitas Kabel Telekomunikasi																		
				7.734	Utilitas Pipa Air Kotor																		
				4.735	Utilitas Pipa Pembawa Bahan Energi lainnya																		
				7.736	Sambungan utilitas																		
				4.737	Dudukan utilitas																		
		3.740	Pengaman Struktur dan Jalan Lingkungan	4.741	Perangkat Pengendali Kelembaban																		
				4.742	Perangkat Penangkal Petir																		
				4.743	Perangkat Perlindungan Korosi dan Biota Laut																		
				4.744	Lubang Ventilasi																		
				4.745	Penutup Lubang Ventilasi																		
		3.750	SMKS (Sistem Monitoring Kesehatan Jembatan)	4.751	Sensor Struktur																		
				4.752	Perangkat Pengukur Beban Kendaraan																		
				4.753	Sensor pengukur Beban Kendaraan																		
				4.754	Pendukung lainnya																		
		3.760	Perlengkapan Jembatan Gerak / moveable bridge	4.755	Perangkat Penyalur Data																		
				4.761	Sistem penggerak fungsional																		
				4.762	Sistem Elektrik																		
				4.763	Sistem Hidrolik																		
				4.764	Sistem Mekanis																		
		3.770	Fasilitas Pemeriksaan Tetap	4.771	Tangga / Platform Pemeriksaan																		
				4.772	Lubang Masuk (gelagar, kolom)																		
				4.773	Traveler																		
2.800	gorong - gorong	3.810	Tanah di dalam struktur Gorong - gorong	4.811	Tanah timbunan di atas gorong - gorong																		
				4.812	Tanah dasar di bawah struktur gorong - gorong																		

LEVEL 3		Nilai Kondisi					
Kode	Elemen	S	R	K	F	P	NK

Elemen		Elemen		Elemen		Kerusakan		Lokasi		Level 5					Level 4													
Kode	Uraian Level 2 (pilihan)	Kode	Uraian Level 3 (pilihan)	Kode	Uraian (pilihan)	Kode	Uraian (pilihan)	A/P/B	X	Y	Z	S	R	K	F	P	NK	S	R	K	F	P	NK					
		3.820	Gorong - gorong Persegi Boks	4.821	Dinding Tegak																							
				4.822	Pelat Bawah																							
				4.823	Pelat Atas																							
				4.824	Drainase Gorong - gorong Persegi Boks																							
		3.830	Gorong - gorong Pipa	4.831	Dinding penahan tanah timbunan																							
				4.832	Drainase Gorong - gorong Pipa																							
		Gorong - gorong Pelengkung Baja Gelombang	4.841	Pelat Baja Gelombang																								
			4.842	Sambungan / Baut pengikat																								
			4.843	Fondasi / Pelat Beton Dudukan Pelengkung Baja Gelombang																								
			4.844	Drainase Gorong gorong Pelengkung Baja Bergelombang																								
		3.850	Struktur Pendukung Gorong gorong	4.851	Tembok Sayap																							
				4.852	Tembok Kepala (Head wall) Gorong-gorong																							
				4.853	Tembok Bawah (Drop wall) Gorong-gorong																							
				4.854	Apron																							
		3.860	Perkuatan Gorong - gorong	4.861	Perkuatan dengan Lapisan Beton Tambahan																							
4.862	Perkuatan dengan FRP																											
4.863	Perkuatan dengan Lapisan Baja Tambahan																											
2.900	Struktur Lintasan B	3.910	Lintasan dengan Perkerasan																									
		3.920	Lintasan Alam (tanpa perkerasan)																									
		3.930	Lintasan dengan struktur semi - permanen																									

LEVEL 3		Nilai Kondisi					
Kode	Elemen	S	R	K	F	P	NK



**PEMERINTAH KOTA SEMARANG  
DINAS PEKERJAAN UMUM**

JL. MADUKORO RAYA NO. 7, TELP. (024) 76433969, FAX. (024) 76433969 KOTA SEMARANG

**NO. JEMBATAN**

:	KT	3	3	0	7	4	0	5	1	0	0	7	0	5	4	0	0	1
---	----	---	---	---	---	---	---	---	---	---	---	---	---	---	---	---	---	---

**NAMA JEMBATAN**

: KALI SRINGIN

**POTONGAN MEMANJANG**

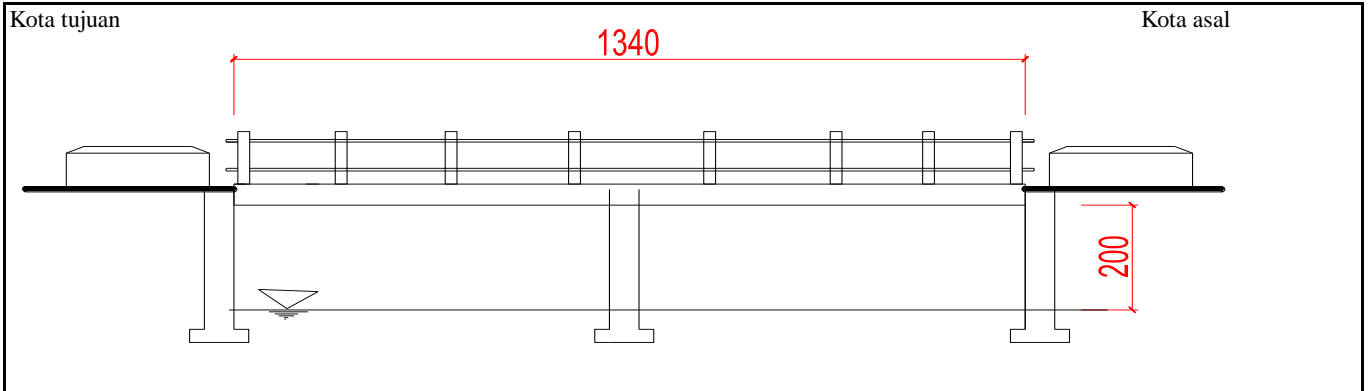

**TAMPAK ATAS**

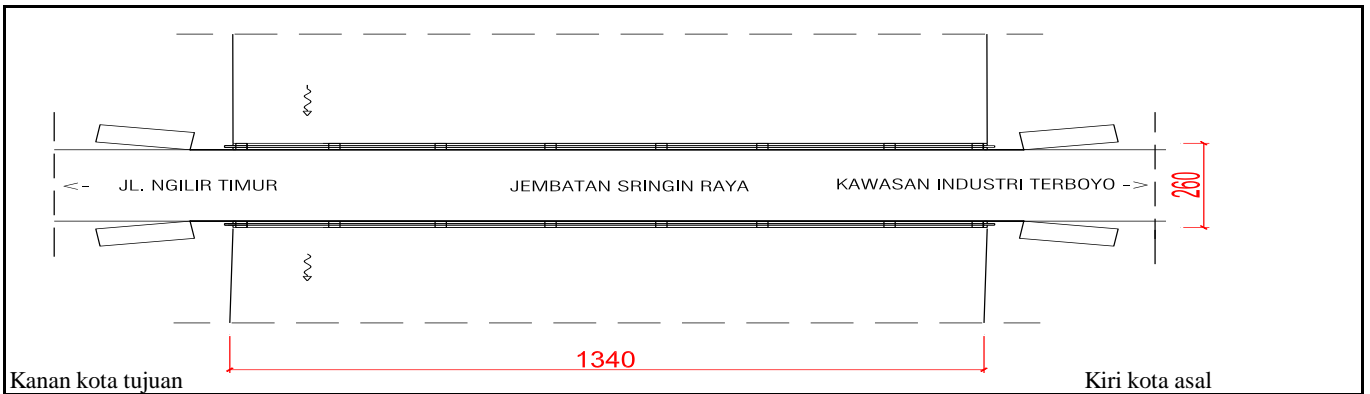

**SITUASI**

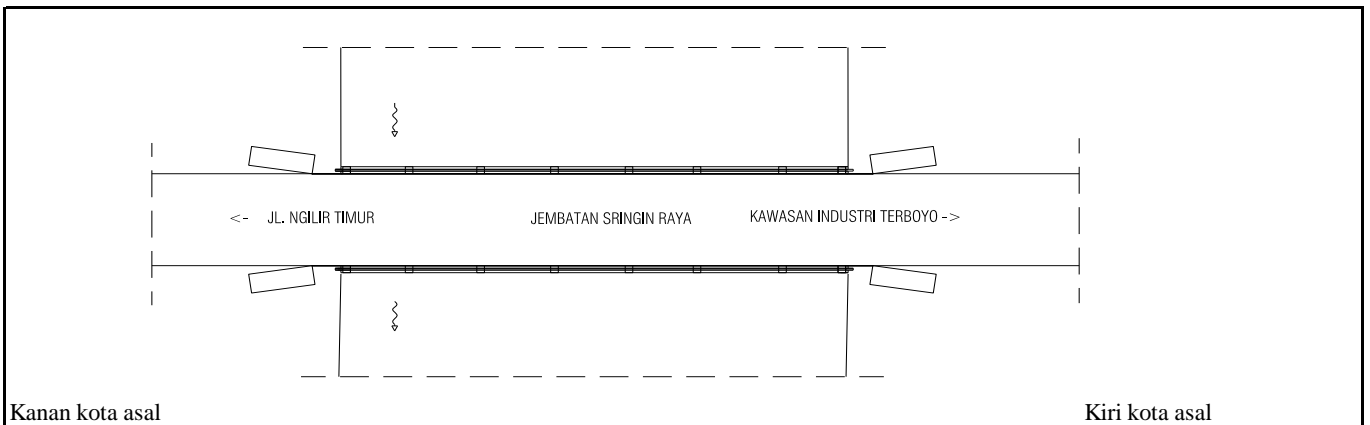





**PEMERINTAH KOTA SEMARANG  
DINAS PEKERJAAN UMUM**

JL. MADUKORO RAYA NO. 7, TELP. (024) 76433969, FAX. (024) 76433969 KOTA SEMARANG



**TAMPAK MEMANJANG**



**TAMPAK MEMANJANG**



**TAMPAK MELINTANG**



**TAMPAK MELINTANG**

NOMOR JEMBATAN	NAMA JEMBATAN	LOKASI ( Km )	PANJANG ( M )
KT.33.074.05.1007.054.001	KALI SRINGIN	0+150	13,40





**PEMERINTAH KOTA SEMARANG  
DINAS PEKERJAAN UMUM**

JL. MADUKORO RAYA NO. 7, TELP. (024) 76433969, FAX. (024) 76433969 KOTA SEMARANG



**JALAN PENDEKAT BERLUBANG**



**LANTAI JEMBATAN PECAH**



**PARAPET PECAH**

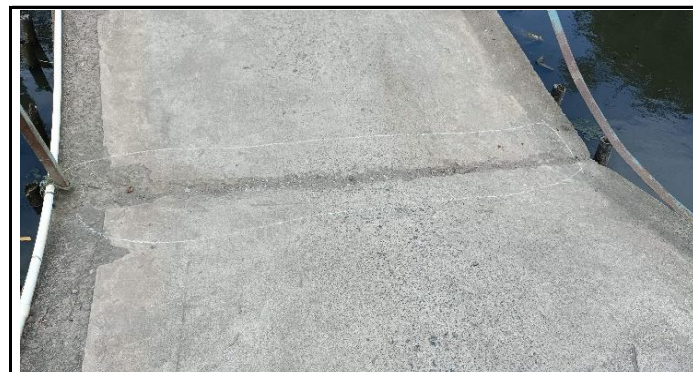

**JEMBATAN RUNTUH**

NOMOR JEMBATAN	NAMA JEMBATAN	LOKASI (Km)	PANJANG (M)
KT.33.074.05.1007.054.001	KALI SRINGIN	0+150	13,40