



**PEMERINTAH KOTA SEMARANG
DINAS PEKERJAAN UMUM**

JL. MADUKORO RAYA NO. 7, TELP. (024) 76433969, FAX. (024) 76433969 KOTA SEMARANG

**FORM INVENTARISASI JEMBATAN
Ruas Jalan
PASAR GENUK**

NO JEMBATAN : KT.33.074.05.1004.245.001
NAMA JEMBATAN : PASAR GENUK 1
TAHUN ANGGARAN : 2024



LAPORAN PEMERIKSAAN INVENTARISASI JEMBATAN

No. Jembatan Ruas Jalan Kabupaten dan Kota

KT	3	3	0	7	4	0	5	1	0	0	4	2	4	5	0	0	1
----	---	---	---	---	---	---	---	---	---	---	---	---	---	---	---	---	---

Nama Jembatan	PASAR GENUK 1				Propinsi / Kabupaten / Kota Semarang				
Lokasi Jembatan	Koordinat Awal : Koordinat Akhir :	-6,9519180 -6,9519180	LS LS	110,4800640 110,4800640	BT BT	Dari (Kota Asal/Km.NoI) :	SMG	Km. (Jarak dari kota asal) :	0+190
Tanggal Pemeriksaan 08/03/2024	Nama Pemeriksa / NIP GENDUT SUMANTO				Tahun Pembangunan -				
Nilai Lalu - Lintas :	-				LHR : -		Tahun : 2019		

INFORMASI PEMBANGUNAN JEMBATAN

1 Tanggal / Bulan / Tahun pembangunan jembatan / pengoperasian pertama kali	:	-		
2 Tanggal / Bulan / Tahun pelebaran/rehabilitasi/perkuatan jembatan / pengoperasian pertama kali	:	-		
3 Tanggal / Bulan / Tahun serah terima aset	:	-		
4 Penanggung jawab pembangunan (Satker/PPK)	:	-		
5 Penanggung jawab pelebaran/rehabilitasi/perkuatan jembatan (Satker/PPK)	:	-		
6 Biaya perencanaan	:	-		
7 Biaya pembangunan	:	-		
8 Biaya pelebaran/rehabilitasi/perkuatan jembatan	:	-		
9 Biaya pengujian	:	-		
10 Nilai aset serah terima	:	-		
11 Nama konsultan perencana pembangunan	:	-		
12 Nama <i>Independent Proof Checker</i> (IPC)	:	-		
13 Nama konsultan perencana pelebaran/rehabilitasi/perkuatan jembatan	:	-		
14 Nama kontraktor pelaksana pembangunan	:	-		
15 Nama kontraktor pelaksana pelebaran/rehabilitasi/perkuatan jembatan	:	-		
16 Nama subkontraktor spesialis	:	-		
17 Nama konsultan pengawas pembangunan	:	-		
18 Nama konsultan pengawas pelebaran/rehabilitasi/perkuatan jembatan	:	-		
19 Nama konsultan pengujian	:	-		
	Tersedia / Tidak			File
20 Laporan pembangunan/pelebaran/rehabilitasi/perkuatan jembatan	:			
21 <i>As-built-drawing</i> atau denah jembatan	:			

Hanya untuk keperluan kantor

Tanggal memasukkan Data Pemeriksaan Inventarisasi 22/03/2024	Oleh : WAHYU DWI S.
---	------------------------



PEMERINTAH KOTA SEMARANG
DINAS PEKERJAAN UMUM

JL. MADUKORO RAYA NO. 7, TELP. (024) 76433969, FAX. (024) 76433969 KOTA SEMARANG

INFORMASI KAPASITAS MUATAN

1 Batasan muatan sumbu terberat MST	: -	ton
2 Beban maksimum yang pernah di atas jembatan	: -	ton
3 Jenis kendaraan berat yang umum lewat di atas jembatan	: -	
4 Tindakan darurat yang sedang/pernah dilakukan di atas jembatan	: D	
a. Pembatasan beban		
b. Penyokongan/Sangga		
c. Penutupan parsial/Sebagian		
d. Penutupan penuh		
e. Jalan Memutar/ <i>detour</i>		
f. Jembatan Sementara		
5 Apakah tersedia jalan memutar/ <i>detour</i> jika jembatan ditutup	Ya	tidak
6 Panjang jarak tambahan yang harus ditempuh dengan jalan memutar	350	m

INFORMASI KAPASITAS LALU LINTAS

1 Lalu - lintas harian rata-rata tahunan (LHR) AADT	: -	
2 Nilai Lalu - Lintas (Perbandingan lebar jalur lalu-lintas yang tersedia di atas jembatan dengan lebar perkerasan sebelum masuk ke dalam jembatan)		
Longgar kendaraan bebas melintas di atas jembatan		0
Cukup lebar kendaraan melaju perlahan di atas jembatan		3
Sempit kendaraan harus antri atau berhenti		5
3 Lebar kendaraan maksimum (<i>ODOL/Over-dimension overload vehicle</i>)	: -	m

INFORMASI BATASAN PERLINTASAN DAN LINGKUNGAN

1 Tinggi muka air banjir terhadap bagian atas lantai jembatan	: -	m
2 Tinggi muka air banjir terhadap elevasi perletakan jembatan	: -	m
3 Tinggi muka air banjir terhadap elevasi terbawah bangunan atas jembatan	: -	m
4 Kedalaman gerusan di sekitar pilar	: -	m
5 Kedalaman gerusan di sekitar kepala jembatan	: -	m
6 Kedalaman gerusan di sekitar tanah timbunan atau bangunan pengaman lainnya	: -	m
7 Tinggi bebas perlintasan <i>overpass</i> jalan	: -	m
8 Tinggi bebas perlintasan kereta api	: -	m
9 Tinggi bagian tertinggi dari kapal laut dan/atau angkutannya terhadap elevasi terbawah bangunan atas jembatan	: -	m
10 Lebar alur pelayaran untuk dibandingkan dengan kapal laut	: -	m
11 Tinggi pilon dengan batasan lintasan pesawat udara dekat bandara	: -	m



PEMERINTAH KOTA SEMARANG
DINAS PEKERJAAN UMUM

JL. MADUKORO RAYA NO. 7, TELP. (024) 76433969, FAX. (024) 76433969 KOTA SEMARANG

KODE-KODE PEMERIKSAAN INVENTARISASI JEMBATAN

Tipe Lintasan		JN (jalan)	SL (sungai lurus)	SM (sungai meander)	SB (sungai berjalın)	S/T (selat atau teluk)	KA (Kereta Api)	L (lain-lain)				
A. TBA (Tipe Bangunan Atas)		B. BHN (Bahan)			C1. SBA (Sifat Bangunan Atas)		C2. Keterangan Detail		D. TF (Tipe Fondasi)		E. KJP (Kepala Jembatan/Pilar)	
B	gorong-gorong persegi	K	Kayu	P	Permanen	A	Australia	CA	Cakar Ayam	A	Cap (Kepala tiang)	
Y	gorong-gorong pipa	S	Pasangan bata	S	Semi Permanen	T	Australia (Sementara)	LS	Langsung		B	Dinding penuh
A	gorong-gorong pelengkung	M	Pasangan batu	W	Darurat	B	Belanda (tipe baru)	TP	Tiang Pancang	K	Kepala jembatan khusus	
T	gantung	G	Bronjong dan sejenisnya	X	Tidak ada struktur	D	Belanda (tipe lama)	PB	Tiang Bor	Pilar		
C	Jembatan Gantungan / Beruji Kabel (Cable Stayed)	H	Pasangan batu kosong	M	Bergerak	I	Indonesia	TU	Tiang Ulir			
G	gelagar	D	Beton tak bertulang	F	Apung	J	Jepang	SU	Sumuran	PILON		
M	gelagar komposit	T	Beton bertulang			R	Austria	LL	Lain-lain			
O	Gelagar Boks	P	Beton pratekan			E	Spanyol			C	Cap (kepala tiang)	
Q	Gelagar tipe U	B	Baja			U	Callender Hamilton (UK/Inggris)			P	Dinding penuh	
L	balok pelengkung	U	Pelat baja gelombang			W	Acrow/Bailey			S	Satu kolom	
E	pelengkung	Y	Komposit Baja - beton							D	Dua kolom	
		J	Alumunium							T	Tiga atau lebih kolom	
		E	Neoprene / karet							L	Lain-lain	
D	Flat Slab	F	Teflon							V	Tipe V	
V	Voided Slab	V	PVC							Tiang Sandaran		
R	rangka	N	geotextile									
P	Pelat	O	Tanah biasa/lempung atau timbunan							TB	tiang beton sandaran baja	
		A	Aspal							BB	tiang baja sandaran baja	
F	ferry	R	kerikil/pasir							DB	dinding bagian bawah + sandaran baja	
K	lintasan kereta api	W	Macadam							DD	Sandaran/Median beton bertulang	
W	lintasan basah	X	Bahan asli							KK	tiang kayu sandaran kayu	
U	lain-lain	L	Lain-lain									

Catatan :
*Asal produksi jembatan,
apabila diketahui pasti, dari
pemeriksaan detail dapat
dituliskan atau diganti dengan
sifat apabila tidak pasti*



**PEMERINTAH KOTA SEMARANG
DINAS PEKERJAAN UMUM**

JL. MADUKORO RAYA NO. 7, TELP. (024) 76433969, FAX. (024) 76433969 KOTA SEMARANG

NO. JEMBATAN :

KT	3	3	0	7	4	0	5	1	0	0	4	2	4	5	0	0	1
----	---	---	---	---	---	---	---	---	---	---	---	---	---	---	---	---	---

NAMA JEMBATAN : PASAR GENUK 1

POTONGAN MEMANJANG

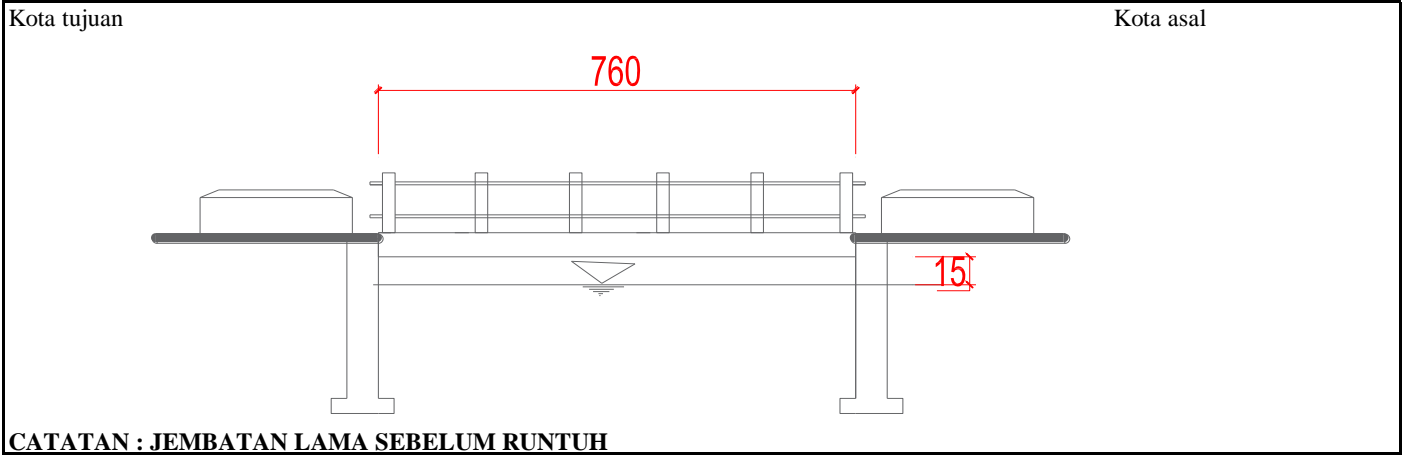

TAMPAK ATAS

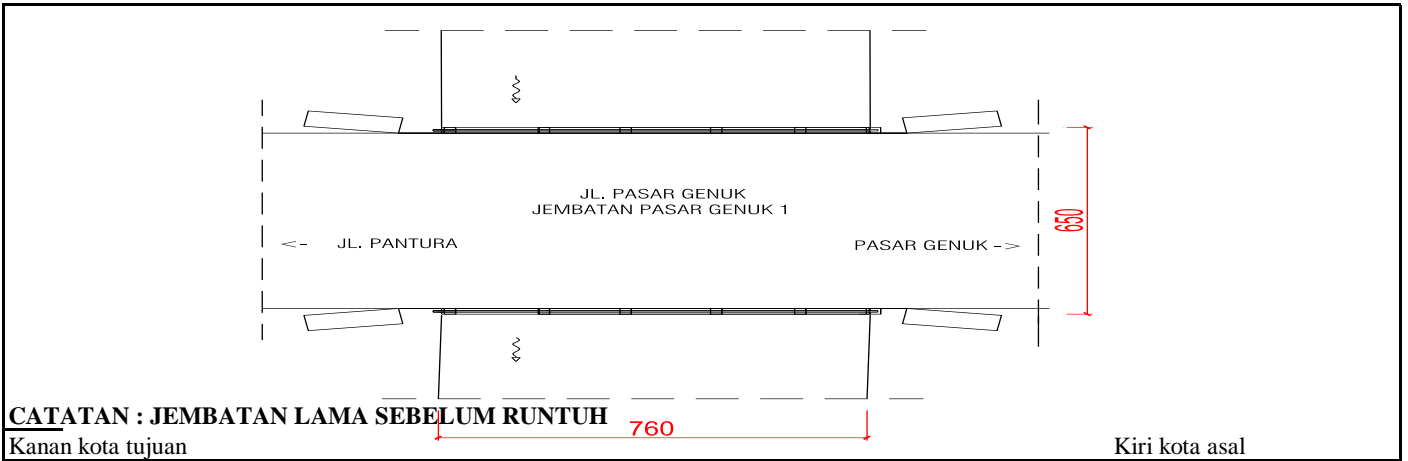

SITUASI

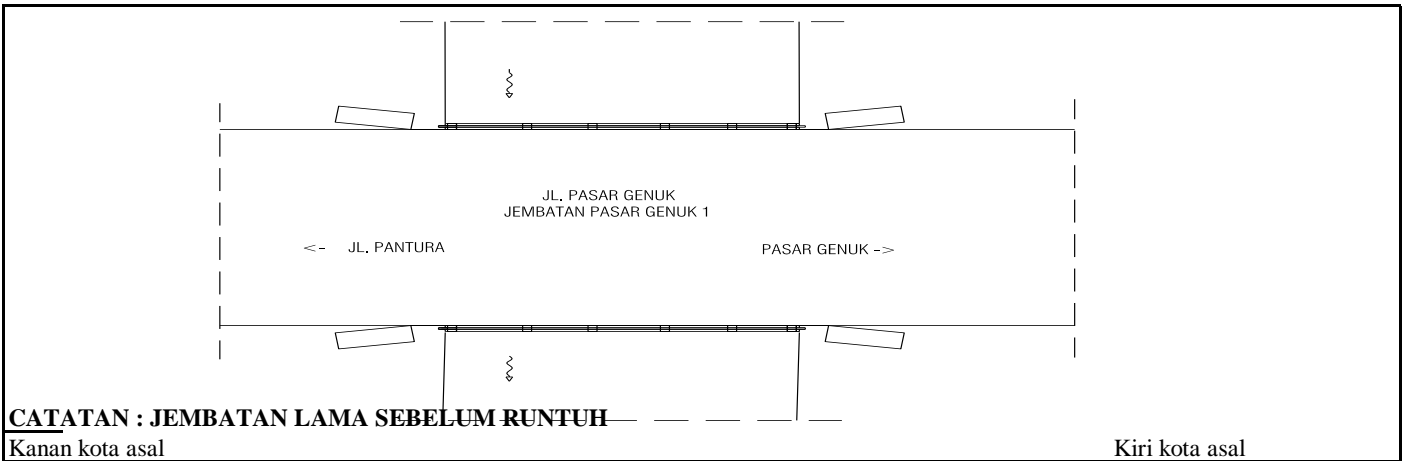



PEMERINTAH KOTA SEMARANG
DINAS PEKERJAAN UMUM

JL. MADUKORO RAYA NO. 7, TELP. (024) 76433969, FAX. (024) 76433969 KOTA SEMARANG



TAMPAK MEMANJANG



TAMPAK MEMANJANG



TAMPAK MELINTANG



TAMPAK MELINTANG

NOMOR JEMBATAN	NAMA JEMBATAN	LOKASI (Km)	PANJANG (M)
KT.33.074.05.1004.245.001	PASAR GENUK 1	0+190	5,00



**PEMERINTAH KOTA SEMARANG
DINAS PEKERJAAN UMUM**

JL. MADUKORO RAYA NO. 7, TELP. (024) 76433969, FAX. (024) 76433969 KOTA SEMARANG



SEDIMENTASI PADA ALIRAN SUNGAI



SEDIMENTASI PADA ALIRAN SUNGAI



**JEMBATAN DARURAT KARENA JEMBATAN
ASLI RUNTUH**



PERKERASAN JALAN PENDEKAT RUSAK

NOMOR JEMBATAN	NAMA JEMBATAN	LOKASI (Km)	PANJANG (M)
KT.33.074.05.1004.245.001	PASAR GENUK 1	0+190	5,00



**PEMERINTAH KOTA SEMARANG
DINAS PEKERJAAN UMUM**

JL. MADUKORO RAYA NO. 7, TELP. (024) 76433969, FAX. (024) 76433969 KOTA SEMARANG

**FORM DETAIL JEMBATAN
Ruas Jalan
PASAR GENUK**

NO JEMBATAN : KT.33.074.05.1004.245.001
NAMA JEMBATAN : PASAR GENUK 1
TAHUN ANGGARAN : 2024



LAPORAN PEMERIKSAAN DETAIL JEMBATAN

No. Jembatan Ruas Jalan Kabupaten dan Kota

KT	3	3	0	7	4	0	5	1	0	0	4	2	4	5	0	0	1
----	---	---	---	---	---	---	---	---	---	---	---	---	---	---	---	---	---

Nama Jembatan	PASAR GENUK 1				Propinsi / Kabupaten / Kota Semarang															
Lokasi Jembatan	Koordinat Awal :	-6,951918	LS	110,480064	BT	Dari (Kota Asal/Km.No1) :	SMG													
	Koordinat Akhir :	-6,951918	LS	110,480064	BT	Km. (Jarak dari kota asal) :	0+190													
Tanggal Pemeriksaan 08 March 2024	Nama Pemeriksa / NIP GENDUT SUMANTO				Tahun Pembangunan															
Nilai Traffic :	-				LHR :				-				Tahun :				2019			

USULAN PEMERIKSAAN KHUSUS

Apakah tindakan darurat disarankan ? Ya Tidak

Elemen elemen yang memerlukan Pemeriksaan Khusus

Kode	Elemen Uraian	Lokasi				Alasan untuk melakukan pemeriksaan khusus
		A/P/B	X	Y	Z	

TINDAKAN DARURAT

Apakah tindakan darurat disarankan ? Ya Tidak

Elemen elemen yang memerlukan Tindakan Darurat

Kode	Elemen Uraian	Lokasi				Alasan untuk melakukan pemeriksaan Darurat
		A/P/B	X	Y	Z	
1.000	Jembatan					Runtuh

Hanya untuk keperluan kantor

Tanggal memasukkan Data Pemeriksaan Inventarisasi 22 March 2024	Oleh : WAHYU DWI S.
--	------------------------

Elemen Kode	Uraian Level 2 (pilihan)	Elemen Kode	Uraian Level 3 (pilihan)	Elemen		Kerusakan		Lokasi															
				Kode	Uraian (pilihan)	Kode	Uraian (pilihan)	Level 5					Level 4										
								Nilai Kondisi										Nilai Kondisi					
A/P/B	X	Y	Z	S	R	K	F	P	NK	S	R	K	F	P	NK								
	3.440	Balok Pelengkung	4.434	Drainase Pelengkung																			
			4.441	balok pelengkung																			
			4.442	Pengaku Balok Pelengkung																			
			4.443	Sambungan Balok Pelengkung																			
			4.444	Balok Pelengkung Rangka Baja																			
			4.445	Pengantung Rangka Baja																			
			4.446	Perkuatan Balok Pelengkung																			
			4.447	Drainase Balok Pelengkung																			
			3.450	Rangka	4.451	Rangka Jembatan Panel																	
					4.451	Rangka Jembatan Panel																	
					4.452	Sambungan Rangka Jembatan Panel																	
					4.453	Struktur Rangka																	
					4.454	Pengaku Rangka																	
					4.455	Sambungan Rangka Baja																	
	4.456	Perkuatan Jembatan Rangka																					
	4.457	Drainase Rangka																					
	3.460	Jembatan - Beruji - Kabel (Cable-stayed)	4.461	Sistem Kabel Jembatan-Beruji-Kabel																			
			4.462	Sistem Penahan Kabel Jembatan-beruji-kabel																			
			4.463	Gelagar Melintang Jembatan Beruji Kabel (Cable stayed)																			
			4.464	Perkuatan Jembatan Beruji Kabel (Cable stayed)																			
	3.470	Jembatan Gantung	4.471	Sistem Kabel Jembatan Gantung																			
			4.472	Batang Penggantung Jembatan Gantung																			
			4.473	Pengaku Jembatan Gantung																			
			4.474	Sistem penahan Kabel Jembatan Gantung																			
			4.475	Perkuatan Jembatan Gantung																			
			4.486	sadel pylon																			
			4.487	balok melintang																			
			4.488	ikatan angin bawah																			
			4.489	gantun/ sambungan																			
	3.480	Pilon	4.481	Struktur Pilon																			
			4.482	Penahan Kabel di Pilon																			
			4.483	Pilon Baja																			
			4.484	Sambungan Pilon Baja																			
			4.485	Perkuatan Pilon																			
			4.486	Drainase pilon																			
	3.490	Gelagar Boks	4.491	Struktur Gelagar Boks																			
			4.492	Pengaku gelagar boks																			
			4.493	Sambungan Gelagar Boks																			
			4.494	Prategang Eksternal dalam gelagar boks																			
			4.495	Perkuatan gelagar boks																			
			4.496	Drainase Gelagar Boks																			
	3.500	Sistem Lantai	4.511	Struktur Lantai			Runtuh				1	1	1	1	1	5	1	1	1	1	1	5	
			4.512	Penyangga Sistem Lantai																			
			4.513	Trottoar dan kerb																			
			4.514	Lapis Permukaan Sistem Lantai			Runtuh					1	1	1	1	1	5	1	1	1	1	1	5
			4.515	Perkuatan Sistem Lantai																			
			4.516	Link Slab																			
4.517			Drainase Lantai																				
3.600	Sambungan/Siar Muai	4.601	Sambungan/Siar Muai Baja (tipe gergaji)																				
		4.602	Sambungan/Siar Muai Baja Siku Profil Terbuka																				
3.610	Landasan/Perletakan	4.611	Landasan																				
		4.612	Peredam Pasif/Damping Struktur																				
		4.613	Peredam Aktif Struktur																				
		4.614	Pendukung landasan																				
		4.615	Penahan pergerakan landasan																				
		4.616	Ikatan / Perletakan Lainnya																				
3.620	Pengaman Pengguna Jalan	4.621	Struktur Sandaran Railing			Runtuh				1	1	1	1	1	5	1	1	1	1	1	5		
		4.622	Struktur tembok																				
		4.623	Pembatas lainnya																				
3.630	Perlengkapan Aerodinamik Jembatan	4.631	Perlengkapan Aerodinamik Bangunan Atas																				
		4.632	Perlengkapan Aerodinamik Permukaan Kabel Jembatan																				
		4.633	Wind Barrier																				
2.700	Perlengkapan	3.710	Perlengkapan Umum	4.711	Perangkat Pengendali Lalu Lintas																		

LEVEL 3		Nilai Kondisi					
Kode	Elemen	S	R	K	F	P	NK
1.000	Jembatan	1	1	1	1	1	5

Elemen		Elemen		Elemen		Kerusakan		Lokasi		Level 5					Level 4									
Kode	Uraian Level 2 (pilihan)	Kode	Uraian Level 3 (pilihan)	Kode	Uraian (pilihan)	Kode	Uraian (pilihan)	Nilai Kondisi					Nilai Kondisi											
								A/P/B	X	Y	Z	S	R	K	F	P	NK	S	R	K	F	P	NK	
				4.712	Penanda Jembatan																			
				4.713	Penunjang Perlengkapan																			
				4.714	Struktur Penutup Jembatan																			
				4.715	Pendukung sandaran / median																			
				4.721	Sistem penerangan																			
		3.720	Penerangan	4.721	Sistem penerangan																			
				4.722	Struktur Tiang Pengaman																			
				4.723	Penunjang Penerangan																			
		3.730	Utilitas	4.731	Utilitas Kabel Listrik																			
				4.732	Utilitas Pipa Air Minum																			
				4.733	Utilitas Kabel Telekomunikasi																			
				7.734	Utilitas Pipa Air Kotor																			
				4.735	Utilitas Pipa Pembawa Bahan Energi lainnya																			
				7.736	Sambungan utilitas																			
				4.737	Dudukan utilitas																			
		3.740	Pengaman Struktur dan Jalan Lingkungan	4.741	Perangkat Pengendali Kelembaban																			
				4.742	Perangkat Penangkal Petir																			
				4.743	Perangkat Perlindungan Korosi dan Biota Laut																			
				4.744	Lubang Ventilasi																			
				4.745	Penutup Lubang Ventilasi																			
		3.750	SMKS (Sistem Monitoring Kesehatan Jembatan)	4.751	Sensor Struktur																			
				4.752	Perangkat Pengukur Beban Kendaraan																			
				4.753	Sensor pengukur Beban Kendaraan																			
				4.754	Pendukung lainnya																			
		3.760	Perlengkapan Jembatan Gerak / moveable bridge	4.755	Perangkat Penyalur Data																			
				4.761	Sistem penggerak fungsional																			
				4.762	Sistem Elektrik																			
				4.763	Sistem Hidrolik																			
				4.764	Sistem Mekanis																			
		3.770	Fasilitas Pemeriksaan Tetap	4.771	Tangga / Platform Pemeriksaan																			
				4.772	Lubang Masuk (gelagar, kolom)																			
				4.773	Traveler																			
2.800	gorong - gorong	3.810	Tanah di dalam struktur Gorong - gorong	4.811	Tanah timbunan di atas gorong - gorong																			
				4.812	Tanah dasar di bawah struktur gorong - gorong																			
		3.820	Gorong - gorong Persegi Boks	4.821	Dinding Tegak																			
				4.822	Pelat Bawah																			
				4.823	Pelat Atas																			
				4.824	Drainase Gorong - gorong Persegi Boks																			
		3.830	Gorong - gorong Pipa	4.831	Dinding penahan tanah timbunan																			
				4.832	Drainase Gorong - gorong Pipa																			
				4.841	Pelat Baja Gelombang																			
				4.842	Sambungan / Baut pengikat																			
				4.843	Fondasi / Pelat Beton Dudukan Pelengkung Baja Gelombang																			
				4.844	Drainase Gorong gorong Pelengkung Baja Bergelombang																			
		3.850	Struktur Pendukung Gorong - gorong	4.851	Tembok Sayap																			
				4.852	Tembok Kepala (Head wall) Gorong-gorong																			
				4.853	Tembok Bawah (Drop wall) Gorong-gorong																			
				4.854	Apron																			
		3.860	Perkuatan Gorong - gorong	4.861	Perkuatan dengan Lapisan Beton Tambahan																			
				4.862	Perkuatan dengan FRP																			
				4.863	Perkuatan dengan Lapisan Baja Tambahan																			
2.900	Struktur Lintasan B	3.910	Lintasan dengan Perkerasan																					
		3.920	Lintasan Alam (tanpa perkerasan)																					
		3.930	Lintasan dengan struktur semi - permanen																					

LEVEL 3		Nilai Kondisi					
Kode	Elemen	S	R	K	F	P	NK



**PEMERINTAH KOTA SEMARANG
DINAS PEKERJAAN UMUM**

JL. MADUKORO RAYA NO. 7, TELP. (024) 76433969, FAX. (024) 76433969 KOTA SEMARANG

NO. JEMBATAN

:

KT	3	3	0	7	4	0	5	1	0	0	4	2	4	5	0	0	1
----	---	---	---	---	---	---	---	---	---	---	---	---	---	---	---	---	---

NAMA JEMBATAN

: PASAR GENUK 1

POTONGAN MEMANJANG

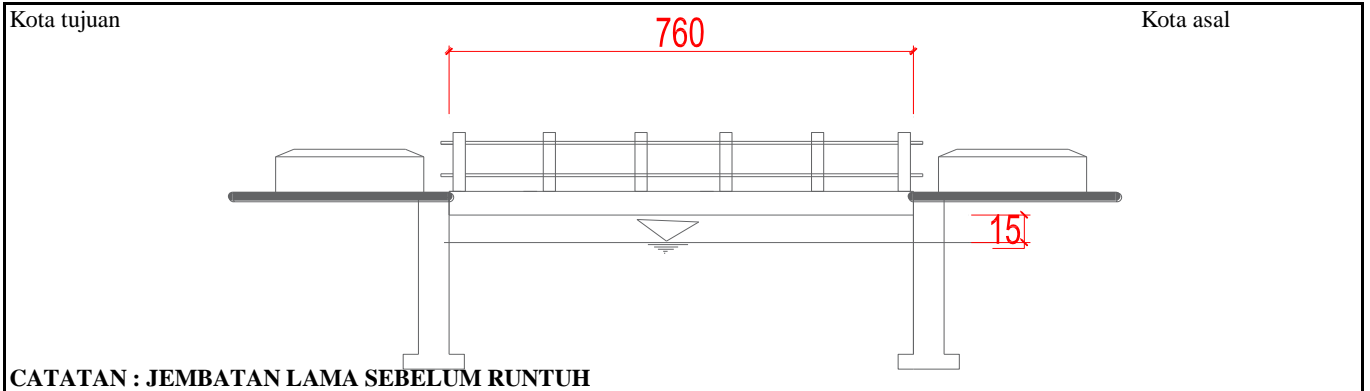

TAMPAK ATAS

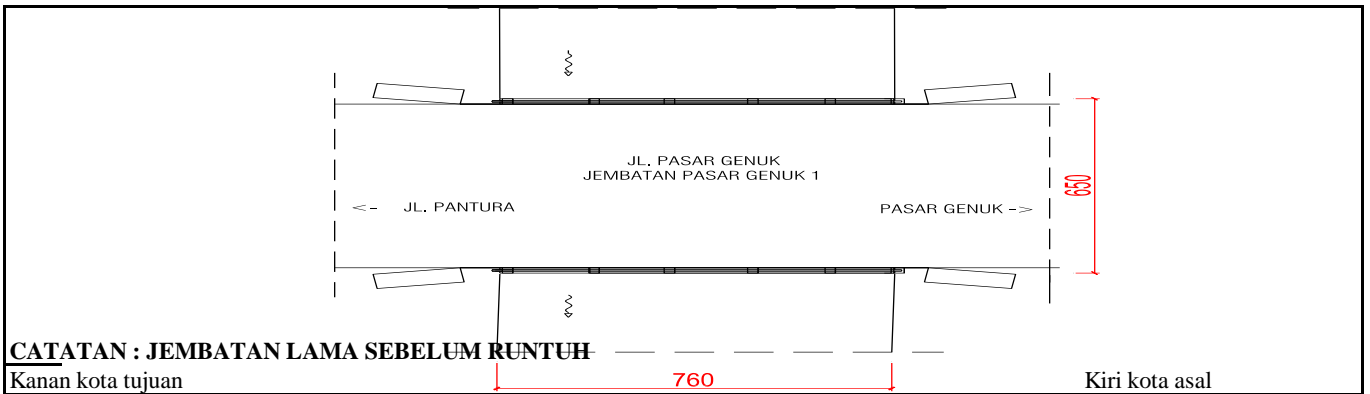

SITUASI





PEMERINTAH KOTA SEMARANG
DINAS PEKERJAAN UMUM

JL. MADUKORO RAYA NO. 7, TELP. (024) 76433969, FAX. (024) 76433969 KOTA SEMARANG



TAMPAK MEMANJANG



TAMPAK MEMANJANG



TAMPAK MELINTANG



TAMPAK MELINTANG

NOMOR JEMBATAN	NAMA JEMBATAN	LOKASI (Km)	PANJANG (M)
KT.33.074.05.1004.245.001	PASAR GENUK 1	0+190	5,00



PEMERINTAH KOTA SEMARANG
DINAS PEKERJAAN UMUM

JL. MADUKORO RAYA NO. 7, TELP. (024) 76433969, FAX. (024) 76433969 KOTA SEMARANG



FOTO KERUSAKAN



FOTO KERUSAKAN



FOTO KERUSAKAN



FOTO KERUSAKAN

NOMOR JEMBATAN	NAMA JEMBATAN	LOKASI (Km)	PANJANG (M)
KT.33.074.05.1004.245.001	PASAR GENUK 1	0+190	5,00