



**PEMERINTAH KOTA SEMARANG**  
**DINAS PEKERJAAN UMUM**

JL. MADUKORO RAYA NO. 7, TELP. (024) 76433969, FAX. (024) 76433969 KOTA SEMARANG

---

**FORM INVENTARISASI JEMBATAN**  
**Ruas Jalan**  
**KEBONHARJO**

**NO JEMBATAN : KT.33.074.02.0023.001**  
**NAMA JEMBATAN : KEBONHARJO**  
**TAHUN ANGGARAN : 2024**



**PEMERINTAH KOTA SEMARANG**  
**DINAS PEKERJAAN UMUM**

JL. MADUKORO RAYA NO. 7, TELP. (024) 76433969, FAX. (024) 76433969 KOTA SEMARANG

SISTEM  
MANAJEMEN  
JEMBATAN



## LAPORAN PEMERIKSAAN INVENTARISASI JEMBATAN

No. Jembatan Ruas Jalan Kabupaten dan Kota

KT	3	3	0	7	4	0	2	0	0	2	3	0	0	1	
----	---	---	---	---	---	---	---	---	---	---	---	---	---	---	--

Nama Jembatan	<b>KEBONHARJO</b>				Provinsi / Kabupaten / Kota Semarang	
Lokasi Jembatan	Koordinat Awal : -6,9570970 LS	110,4272230 BT	Dari (Kota Asal/Km.NoI) : SMG		Km. (Jarak dari kota asal) : 1+060	
	Koordinat Akhir : -6,9570970 LS	110,4272230 BT				
Tanggal Pemeriksaan 22/03/2024	Nama Pemeriksa / NIP GENDUT SUMANTO				Tahun Pembangunan -	
Nilai Lalu - Lintas :	0.216187	LHR : 910.86	Tahun :		2019	

### INFORMASI PEMBANGUNAN JEMBATAN

1	Tanggal / Bulan / Tahun pembangunan jembatan / pengoperasian pertama kali	:	-
2	Tanggal / Bulan / Tahun pelebaran/rehabilitasi/perkuatan jembatan / pengoperasian pertama kali	:	-
3	Tanggal / Bulan / Tahun serah terima aset	:	-
4	Penanggung jawab pembangunan (Satker/PPK)	:	-
5	Penanggung jawab pelebaran/rehabilitasi/perkuatan jembatan (Satker/PPK)	:	-
6	Biaya perencanaan	:	-
7	Biaya pembangunan	:	-
8	Biaya pelebaran/rehabilitasi/perkuatan jembatan	:	-
9	Biaya pengujian	:	-
10	Nilai aset serah terima	:	-
11	Nama konsultan perencana pembangunan	:	-
12	Nama <i>Independent Proof Checker</i> (IPC)	:	-
13	Nama konsultan perencana pelebaran/rehabilitasi/perkuatan jembatan	:	-
14	Nama kontraktor pelaksana pembangunan	:	-
15	Nama kontraktor pelaksana pelebaran/rehabilitasi/perkuatan jembatan	:	-
16	Nama subkontraktor spesialis	:	-
17	Nama konsultan pengawas pembangunan	:	-
18	Nama konsultan pengawas pelebaran/rehabilitasi/perkuatan jembatan	:	-
19	Nama konsultan pengujian	:	-
		Tersedia / Tidak	File
20	Laporan pembangunan/pelebaran/rehabilitasi/perkuatan jembatan	:	TIDAK
21	<i>As-built-drawing</i> atau denah jembatan	:	TIDAK

Hanya untuk keperluan kantor

Tanggal memasukkan Data Pemeriksaan Inventarisasi 03/04/2024	Oleh : WAHYU DWIS
-----------------------------------------------------------------	----------------------



**PEMERINTAH KOTA SEMARANG**  
**DINAS PEKERJAAN UMUM**

JL. MADUKORO RAYA NO. 7, TELP. (024) 76433969, FAX. (024) 76433969 KOTA SEMARANG

**INFORMASI KAPASITAS MUATAN**

1 Batasan muatan sumbu terberat MST	:	5	ton
2 Beban maksimum yang pernah di atas jembatan	:	5	ton
3 Jenis kendaraan berat yang umum lewat di atas jembatan	:	TRUK	
4 Tindakan darurat yang sedang/pernah dilakukan di atas jembatan	:	E	
a. Pembatasan beban			
b. Penyokongan/Sangga			
c. Penutupan parsial/Sebagian			
d. Penutupan penuh			
e. Jalan Memutar/ <i>detour</i>			
f. Jembatan Sementara			
5 Apakah tersedia jalan memutar/ <i>detour</i> jika jembatan ditutup		Ya	tidak
6 Panjang jarak tambahan yang harus ditempuh dengan jalan memutar		50	m

**INFORMASI KAPASITAS LALU LINTAS**

1 Lalu - lintas harian rata-rata tahunan (LHR) AADT	:	910.86	
2 Nilai Lalu - Lintas (Perbandingan lebar jalur lalu-lintas yang tersedia di atas jembatan dengan lebar perkerasan sebelum masuk ke dalam jembatan			
Longgar kendaraan bebas melintas di atas jembatan		0	
Cukup lebar kendaraan melaju perlahan di atas jembatan		3	
Sempit kendaraan harus antri atau berhenti		5	
3 Lebar kendaraan maksimum ( <i>ODOL/Over-dimension overload vehicle</i> )	:	2,4	m

**INFORMASI BATASAN PERLINTASAN DAN LINGKUNGAN**

1 Tinggi muka air banjir terhadap bagian atas lantai jembatan	:	1	m
2 Tinggi muka air banjir terhadap elevasi perletakan jembatan	:	-	m
3 Tinggi muka air banjir terhadap elevasi terbawah bangunan atas jembatan	:	0,7	m
4 Kedalaman gerusan di sekitar pilar	:	-	m
5 Kedalaman gerusan di sekitar kepala jembatan	:	-	m
6 Kedalaman gerusan di sekitar tanah timbunan atau bangunan pengaman lainnya	:	-	m
7 Tinggi bebas perlintasan <i>overpass</i> jalan	:	-	m
8 Tinggi bebas perlintasan kereta api	:	-	m
9 Tinggi bagian tertinggi dari kapal laut dan/atau angkutannya terhadap elevasi terbawah bangunan atas jembatan	:	-	m
10 Lebar alur pelayaran untuk dibandingkan dengan kapal laut	:	-	m
11 Tinggi pilon dengan batasan lintasan pesawat udara dekat bandara	:	-	m



**PEMERINTAH KOTA SEMARANG**  
**DINAS PEKERJAAN UMUM**

JL. MADUKORO RAYA NO. 7, TELP. (024) 76433969, FAX. (024) 76433969 KOTA SEMARANG

**KODE-KODE PEMERIKSAAN INVENTARISASI JEMBATAN**

Tipe Lintasan		JN (jalan)	SL (sungai lurus)	SM (sungai meander)	SB (sungai berjaln)	S/T (selat atau teluk)	KA (Kereta Api)	L (lain-lain)					
<b>A. TBA (Tipe Bangunan Atas)</b>		<b>B. BHN (Bahan)</b>			<b>C1. SBA (Sifat Bangunan Atas)</b>		<b>C2. Keterangan Detail</b>		<b>D. TF (Tipe Fondasi)</b>		<b>E. KJP (Kepala Jembatan/Pilar)</b>		
B	gorong-gorong persegi	K	Kayu	P	Permanen	A	Australia	CA	Cakar Ayam	A	Cap (Kepala tiang)		
Y	gorong-gorong pipa	S	Pasangan bata	S	Semi Permanen	T	Australia (Sementara)	LS	Langsung		B	Dinding penuh	
A	gorong-gorong pelengkung	M	Pasangan batu	W	Darurat	B	Belanda (tipe baru)	TP	Tiang Pancang		K	Kepala jembatan khusus	
T	gantung	G	Bronjong dan sejenisnya	X	Tidak ada struktur	D	Belanda (tipe lama)	PB	Tiang Bor	<b>Pilar</b>			
C	Jembatan Gantungan / Beruji Kabel (Cable Stayed)	H	Pasangan batu kosong	M	Bergerak	I	Indonesia	TU	Tiang Ulir				
G	gelagar	D	Beton tak bertulang	F	Apung	J	Jepang	SU	Sumuran	<b>PILON</b>			
M	gelagar komposit	T	Beton bertulang			R	Austria	LL	Lain-lain				
O	Gelagar Boks	P	Beton pratekan			E	Spanyol			C	Cap (kepala tiang)		
Q	Gelagar tipe U	B	Baja			U	Callender Hamilton (UK/Inggris)				P	Dinding penuh	
L	balok pelengkung	U	Pelat baja gelombang			W	Acrow/Bailey			S	Satu kolom		
E	pelengkung	Y	Komposit Baja - beton							A	Tipe A	D	Dua kolom
		J	Alumunium						D	Tipe Diamond	T	Tiga atau lebih kolom	
D	Flat Slab	E	Neoprene / karet						H	Tipe H	L	Lain-lain	
V	Voided Slab	F	Teflon						I	Tipe Tunggal / I	V	Tipe V	
R	rangka	V	PVC						Y	Tipe Y	<b>Tiang Sandaran</b>		
P	Pelat	N	geotextile						V	Tipe V terbuka			
		O	Tanah biasa/lempung atau timbunan						W	Tipe Double I	TB	tiang beton sandaran baja	
F	ferry	A	Aspal								BB	tiang baja sandaran baja	
K	lintasan kerata api	R	kerikil/pasir								DB	dinding bagian bawah + sandaran baja	
		W	Macadam								DD	Sandaran/Median beton bertulang	
W	lintasan basah	X	Bahan asli								KK	tiang kayu sandaran kayu	
U	lain-lain	L	Lain-lain										

*Catatan :  
...  
apabila diketahui pasti, dari pemeriksaan detail dapat dituliskan atau diganti dengan sifat apabila tidak pasti*







**PEMERINTAH KOTA SEMARANG**  
**DINAS PEKERJAAN UMUM**

JL. MADUKORO RAYA NO. 7, TELP. (024) 76433969, FAX. (024) 76433969 KOTA SEMARANG

NO. JEMBATAN :

KT	3	3	0	7	4	0	2	0	0	2	3	0	0	1	0
----	---	---	---	---	---	---	---	---	---	---	---	---	---	---	---

NAMA JEMBATAN :

KEBONHARJO

**POTONGAN MEMANJANG**

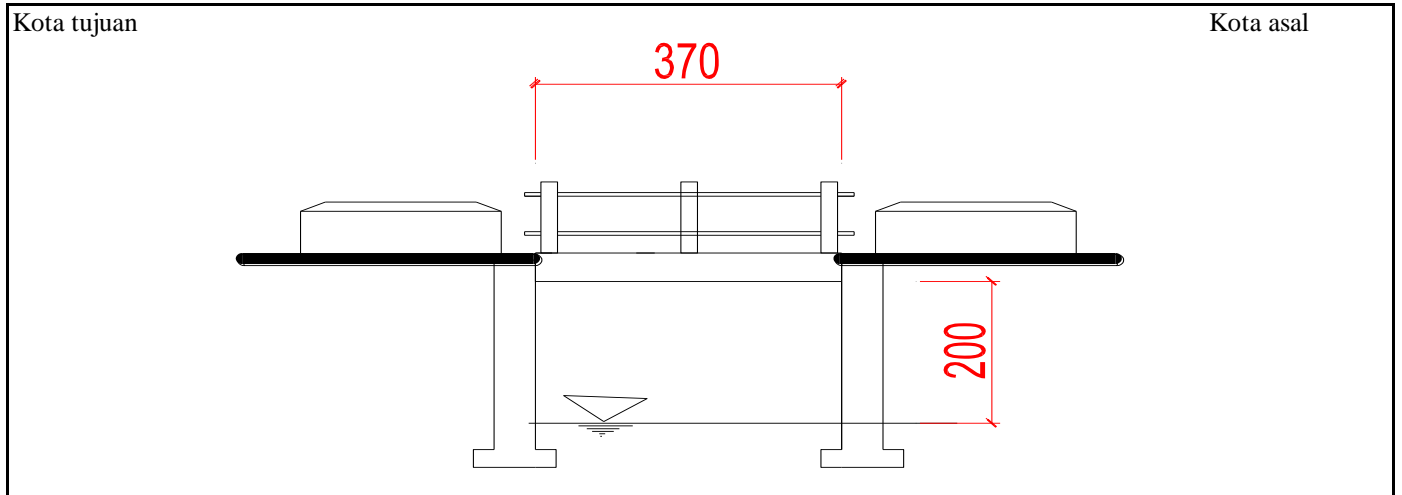

**TAMPAK ATAS**

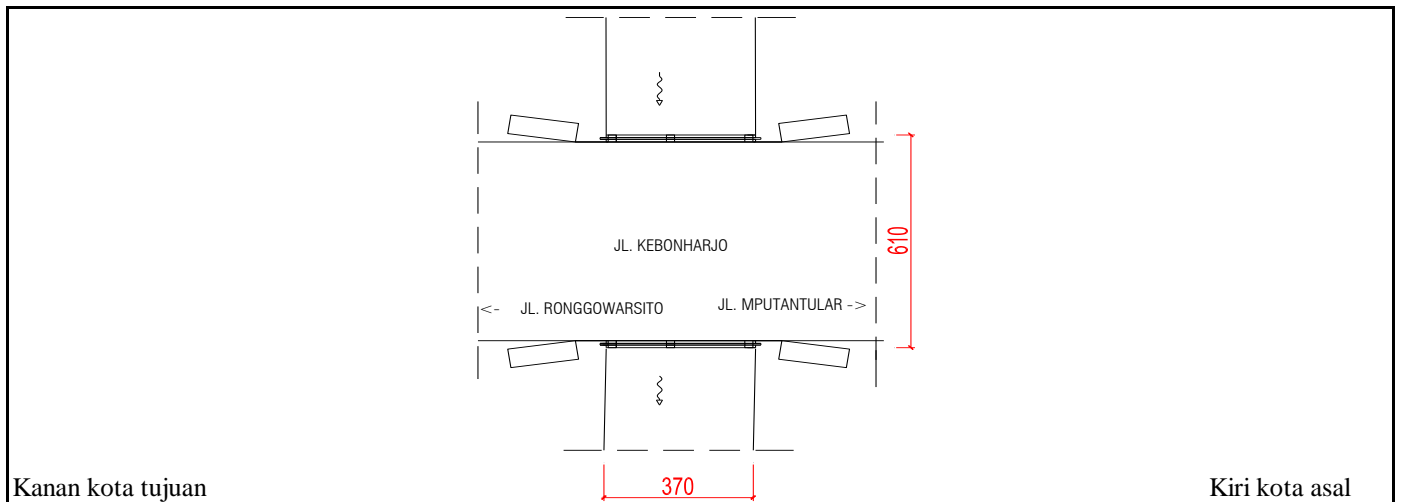

**SITUASI**

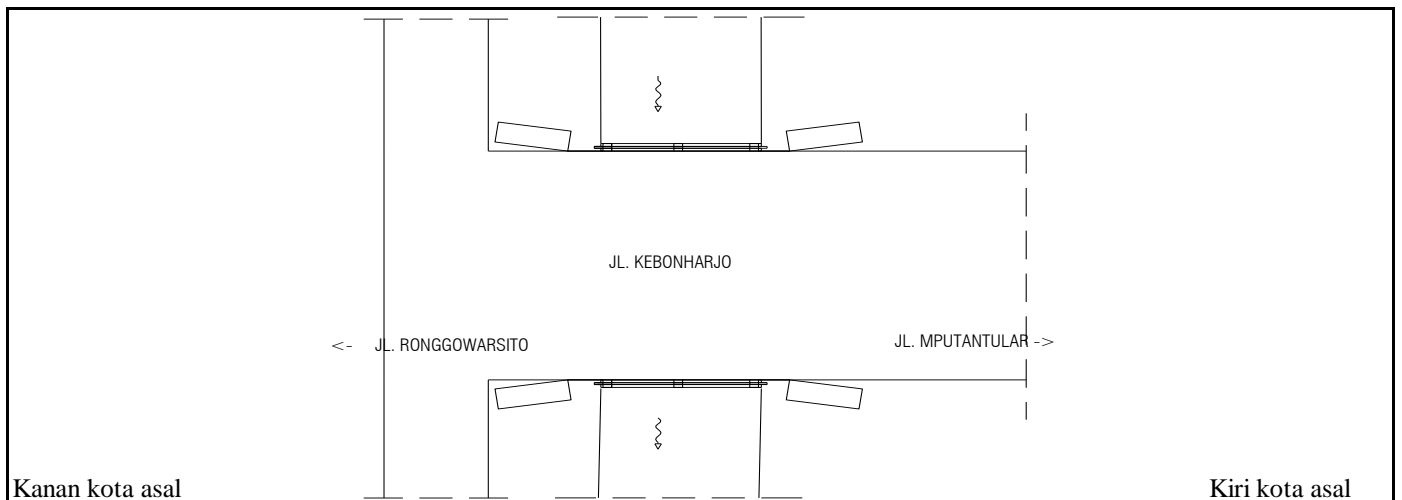



**PEMERINTAH KOTA SEMARANG**  
**DINAS PEKERJAAN UMUM**

JL. MADUKORO RAYA NO. 7, TELP. (024) 76433969, FAX. (024) 76433969 KOTA SEMARANG



**TAMPAK MEMANJANG**



**TAMPAK MEMANJANG**



**TAMPAK MELINTANG**



**TAMPAK MELINTANG**

<b>NOMOR JEMBATAN</b>	<b>NAMA JEMBATAN</b>	<b>LOKASI (Km)</b>	<b>PANJANG (M)</b>
KT.33.074.02.0023.001	KEBONHARJO	1+060	3,70





**PEMERINTAH KOTA SEMARANG**  
**DINAS PEKERJAAN UMUM**

JL. MADUKORO RAYA NO. 7, TELP. (024) 76433969, FAX. (024) 76433969 KOTA SEMARANG



**TEMBOK SEDADA RUNTUH**



**PENDANGKALAN PADA ALIRAN SUNGAI**



**KEPALA JEMBATAN MENGALAMI  
KERONTOKAN ELEMEN**



**PELAT JEMBATAN KEROPOS**

<b>NOMOR JEMBATAN</b>	<b>NAMA JEMBATAN</b>	<b>LOKASI (Km)</b>	<b>PANJANG (M)</b>
KT.33.074.02.0023.001	KEBONHARJO	1+060	3,70



**PEMERINTAH KOTA SEMARANG  
DINAS PEKERJAAN UMUM**

JL. MADUKORO RAYA NO. 7, TELP. (024) 76433969, FAX. (024) 76433969 KOTA SEMARANG

---

**FORM DETAIL JEMBATAN  
Ruas Jalan  
KEBONHARJO**

**NO JEMBATAN : KT.33.074.02.0023.001**  
**NAMA JEMBATAN : KEBONHARJO**  
**TAHUN ANGGARAN : 2024**



**PEMERINTAH KOTA SEMARANG  
DINAS PEKERJAAN UMUM**

JL. MADUKORO RAYA NO. 7, TELP. (024) 76433969, FAX. (024) 76433969 KOTA SEMARANG

SISTEM  
MANAJEMEN  
JEMBATAN



## LAPORAN PEMERIKSAAN DETAIL JEMBATAN

No. Jembatan Ruas Jalan Kabupaten dan Kota

KT	3	3	0	7	4	0	2	0	0	2	3	0	0	1	
----	---	---	---	---	---	---	---	---	---	---	---	---	---	---	--

Nama Jembatan	KEBONHARJO				Propinsi / Kabupaten / Kota Semarang	
Lokasi Jembatan	Koordinat Awal :	-6,957097	LS	110,427223	BT	Dari (Kota Asal/Km.NoI) : SMG
	Koordinat Akhir :	-6,957097	LS	110,427223	BT	Km. (Jarak dari kota asal) : 1+060
Tanggal Pemeriksaan 22 March 2024	Nama Pemeriksa / NIP GENDUT SUMANTO				Tahun Pembangunan	
Nilai Traffic :	0.216187	LHR :	910.86	Tahun :		2019

### USULAN PEMERIKSAAN KHUSUS

Apakah tindakan darurat disarankan ?	<b>Ya</b>	Tidak
--------------------------------------	-----------	-------

#### Elemen elemen yang memerlukan Pemeriksaan Khusus

Kode	Elemen Uraian	Lokasi				Alasan untuk melakukan pemeriksaan khusus
		A/P/B	X	Y	Z	
4.211	tebing sungai					Pengikisan di sepanjang aliran sungai (contraction scour)
4.212	aliran air utama					Pendangkalan sungai akibat endapan (agradasi)
4.222	Pengaman Tebing Sungai					Pengikisan di sepanjang aliran sungai (contraction scour)
4.313	Fondasi Langsung					Pengikisan di sekitar jembatan (local scour)
4.322	Dinding kepala jembatan / pilar					Cacat pada beton termasuk beton rontok / spalling, keropos, berongga, dan kualitas beton yang rendah
4.421	pelat beton bertulang					Cacat pada beton termasuk beton rontok / spalling, keropos, berongga, dan kualitas beton yang rendah
4.511	Struktur Lantai					Cacat pada beton termasuk beton rontok / spalling, keropos, berongga, dan kualitas beton yang rendah

### TINDAKAN DARURAT

Apakah tindakan darurat disarankan ?	Ya	<b>Tidak</b>
--------------------------------------	----	--------------

#### Elemen elemen yang memerlukan Tindakan Darurat

Kode	Elemen Uraian	Lokasi				Alasan untuk melakukan pemeriksaan khusus
		A/P/B	X	Y	Z	

Hanya untuk keperluan kantor

Tanggal memasukkan Data Pemeriksaan Inventarisasi 03 April 2024	Oleh : WAHYU DWIS
--------------------------------------------------------------------	----------------------

LAPORAN PEMERIKSAAN MENDETAIL JEMBATAN

DAFTAR KERUSAKAN UNTUK LEVEL 3-5

No. Jembatan	KT	3	3	0	7	4	0	2	0	0	2	3	0	0	1
--------------	----	---	---	---	---	---	---	---	---	---	---	---	---	---	---

EVALUASI ELEMEN

Elemen	Kode	Uraian Level 2 (pilihan)	Elemen	Kode	Uraian Level 3 (pilihan)	Elemen	Kode	Uraian (pilihan)	Kerusakan	Kode	Uraian (pilihan)	Lokasi																		
												Level 5										Level 4								
												Nilai Kondisi					Nilai Kondisi					S	R	K	F	P	NK			
A/P/B	X	Y	Z	S	R	K	F	P	NK	S	R	K	F	P	NK															
2.100	Jalan Pendekat	3.110	Perkerasan Jalan Pendekat	4.111	Perkerasan Fleksibel Jalan Pendekat	202	Retak (elemen beton)					1	1	0	0	0	2	1	1	0	0	0	2							
				4.112	Perkerasan Kaku Jalan Pendekat																									
				4.113	Pelat Injak																									
				4.114	Sleeper Slab																									
				4.115	Drainase Perkerasan																									
				3.120	Tanah Timbunan	4.121	Tanah Timbunan																							
						4.122	Timbunan Ringan																							
						4.123	Geosintetik																							
						4.124	Drainase Tanah Timbunan																							
				3.130	Struktur Penahan Tanah Jalan Pendekat	4.131	Dinding Penahan Tanah																							
						4.132	Tanah Bertulang/Mechanically Stabilized Earth (MSE)																							
						4.133	Drainase Struktur Penahan Tanah																							
						4.134	Soil nailing																							
				3.140	Pengaman lalu - lintas	4.141	Tiang Pengaman Jalan Pendekat																							
4.142	Pagar Pengaman/Guardrail Jalan Pendekat																													
2.200	Aliran Sungai	3.210	Aliran Sungai	4.211	tebing sungai	503	Pengikisan di sepanjang aliran sungai (contraction scour)					1	1	1	0	0	3	1	1	1	0	0	3							
				4.212	aliran air utama	501	Pendangkalan sungai akibat endapan (agradasi)							1	1	1	0	0	3	1	1	1	0	0	3					
				4.213	daerah genangan banjir																									
		3.220	Bangunan Pengaman	4.221	Pengaman Aliran Sungai																									
				4.222	Pengaman Tebing Sungai	503	Pengikisan di sepanjang aliran sungai (contraction scour)							1	1	1	0	0	3	1	1	1	0	0	3					
				4.223	Pengaman Bangunan Bawah																									
				4.224	Perkuatan bangunan Pengaman																									
				4.225	Pengaman Bangunan Bawah																									
2.300	Bangunan Bawah	3.310	Pondasi	4.311	Fondasi Tiang																									
				4.312	Fondasi Sumuran																									
				4.313	Fondasi Langsung	521	Pengikisan di sekitar jembatan (local scour)							1	1	1	0	0	3	1	1	1	0	0	3					
				4.314	Pondasi Balok Pelengkung																									
				4.315	Sambungan Fondasi dan Lainnya																									
				4.316	Perkuatan Fondasi																									
				4.317	Struktur jembatan apung																									
				3.320	Kepala Jembatan/Pilar	4.321	Balok Fondasi																							
		4.322	Dinding kepala jembatan / pilar			201	Cacat pada beton termasuk beton rontok / spalling, keropos, berongga, dan kualitas beton yang rendah							1	1	1	0	0	3	1	1	1	0	0	3					
		4.323	Balok Kepala Jembatan/Pilar																											
		4.324	Struktur pengaku																											
		4.325	Sambungan kepala jembatan / pilar																											
		4.326	Perkuatan bangunan bawah																											
		2.400	Bangunan Atas	3.410	Sistem Gelagar	4.411	Gelagar utama																							
4.412	Diafragma																													
4.413	Pengaku gelagar baja																													
4.414	Perkuatan gelagar																													
4.415	Sambungan gelagar																													
4.416	Drainase Gelagar																													
3.420	Jembatan Pelat	4.421	pelat beton bertulang	201	Cacat pada beton termasuk beton rontok / spalling, keropos, berongga, dan kualitas beton yang rendah							1	1	1	0	0	3	1	1	1	0	0	3							
		4.422	Pelat beton pracetak pratekan																											
		4.423	Kabel prategang melintang																											
		4.424	Shear key (sambungan antar pelat beton pracetak pratekan - flat slab, )																											
		4.425	Perkuatan Jembatan Pelat																											

Kode	Elemen	LEVEL 3					Nilai Kondisi					
		S	R	K	F	P	S	R	K	F	P	NK
3.110	Perkerasan Jalan Pendekat	1	1	0	0	0	2					
3.120	Tanah Timbunan											
3.130	Struktur Penahan Tanah Jalan Pendekat											
3.140	Pengaman lalu-lintas											
3.210	Aliran Sungai	1	1	1	0	0	3					
3.220	Bangunan Pengaman	1	1	1	0	0	3					
3.310	Fondasi	1	1	1	0	0	3					
3.320	Kepala Jembatan/Pilar	1	1	1	0	0	3					
3.410	Sistem Gelagar											
3.420	Jembatan Pelat	1	1	1	0	0	3					
3.430	Pelengkung											
3.440	Balok Pelengkung											
3.450	Rangka											
3.460	Jembatan Beruji Kabel (Cable-Stayed)											
3.470	Jembatan Gantung											
3.480	Pilon											
3.490	Gelagar Boks											
3.500	Sistem Lantai	1	1	1	0	0	3					
3.600	Sambungan / Siar muai											
3.610	Perletakan											
3.620	Pengaman Pengguna Jalan	1	1	0	0	0	2					
3.630	Perlengkapan Aerodinamik Jembatan											
3.710	Perlengkapan Umum											
3.720	Penerangan											
3.730	Utilitas	1	1	1	0	0	3					
3.740	Pengaman struktur dan lingkungan											
3.750	SMKS (Sistem Monitoring Kesehatan Jembatan)											
3.760	Perlengkapan Jembatan Gerak/moveable bridge											
3.770	Fasilitas Pemeriksaan Tetap											
3.810	Tanah di dalam struktur Gorong-gorong											
3.820	Gorong - gorong persegi Boks											
3.830	Gorong - gorong pipa											
3.840	Gorong - gorong Pelengkung Baja Gelombang											
3.850	Struktur Pendukung Gorong-gorong											
3.860	Perkuatan gorong - gorong											
3.910	Lintasan dengan perkerasan											
3.920	Lintasan alam (tanpa perkerasan)											
3.930	Lintasan dengan struktur semi - permanen											

Kode	Elemen	LEVEL 2					Nilai Kondisi					
		S	R	K	F	P	S	R	K	F	P	NK
2.100	Jalan Pendekat	1	1	0	0	0	2					
2.200	Aliran Sungai	1	1	1	0	0	3					
2.300	Bangunan Bawah	1	1	1	0	0	3					
2.400	Bangunan Atas	1	1	1	0	0	3					
2.700	Perlengkapan	1	1	1	0	0	3					

Elemen		Elemen		Elemen		Kerusakan		Lokasi		Level 5					Level 4									
Kode	Uraian Level 2 (pilihan)	Kode	Uraian Level 3 (pilihan)	Kode	Uraian (pilihan)	Kode	Uraian (pilihan)			Nilai Kondisi					Nilai Kondisi									
								A/P/B	X	Y	Z	S	R	K	F	P	NK	S	R	K	F	P	NK	
		3.430	Pelengkung	4.426	Drainase Jembatan Pelat																			
				4.431	Pelengkung																			
				4.432	Dinding pelengkung																			
				4.433	Perkuatan pelengkung																			
				4.434	Drainase Pelengkung																			
		3.440	Balok Pelengkung	4.441	balok pelengkung																			
				4.442	Pengaku Balok Pelengkung																			
				4.443	Sambungan Balok Pelengkung																			
				4.444	Balok Pelengkung Rangka Baja																			
				4.445	Penggantung Rangka Baja																			
				4.446	Perkuatan Balok Pelengkung																			
				4.447	Drainase Balok Pelengkung																			
		3.450	Rangka	4.451	Rangka Jembatan Panel																			
				4.451	Rangka Jembatan Panel																			
				4.452	Sambungan Rangka Jembatan Panel																			
				4.453	Struktur Rangka																			
				4.454	Pengaku Rangka																			
				4.455	Sambungan Rangka Baja																			
				4.456	Perkuatan Jembatan Rangka																			
				4.457	Drainase Rangka																			
		3.460	Jembatan - Beruji - Kabel (Cable-stayed)	4.461	Sistem Kabel Jembatan-Beruji-Kabel																			
				4.462	Sistem Penahan Kabel Jembatan-beruji-kabel																			
				4.463	Gelagar Melintang Jembatan Beruji Kabel (Cable stayed)																			
				4.464	Perkuatan Jembatan Beruji Kabel (Cable stayed)																			
		3.470	Jembatan Gantung	4.471	Sistem Kabel Jembatan Gantung																			
				4.472	Batang Penggantung Jembatan Gantung																			
				4.473	Pengaku Jembatan Gantung																			
				4.474	Sistem penahan Kabel Jembatan Gantung																			
				4.475	Perkuatan Jembatan Gantung																			
				4.486	sadel pylon																			
				4.487	balok melintang																			
				4.488	ikatan angin bawah																			
				4.489	gantung/ sambungan																			
		3.480	Pilon	4.481	Struktur Pilon																			
				4.482	Penahan Kabel di Pilon																			
				4.483	Pilon Baja																			
				4.484	Sambungan Pilon Baja																			
				4.485	Perkuatan Pilon																			
				4.486	Drainase pilon																			
		3.490	Gelagar Boks	4.491	Struktur Gelagar Boks																			
				4.492	Pengaku gelagar boks																			
				4.493	Sambungan Gelagar Boks																			
				4.494	Prategang Eksternal dalam gelagar boks																			
				4.495	Perkuatan gelagar boks																			
				4.496	Drainase Gelagar Boks																			
		3.500	Sistem Lantai	4.511	Struktur Lantai	201	Cacat pada beton termasuk beton rontok /spalling, keropos, berongga, dan kualitas beton yang rendah					1	1	1	0	0	3	1	1	1	0	0	3	
				4.512	Pencegahan Sistem Lantai																			
				4.513	Trottoar dan kerb																			
				4.514	Lapis Permukaan Sistem Lantai	723	Lapis permukaan yang bergelombang dan alur dari jalur roda (rutting)					1	1	0	0	0	2	1	1	0	0	0	2	
				4.515	Perkuatan Sistem Lantai																			
				4.516	Lank Slab																			
				4.517	Drainase Lantai																			
		3.600	Sambungan/Siar Muai	4.601	Sambungan/Siar Muai Baja (tipe zergani)																			
				4.602	Sambungan/Siar Muai Baja Siku Profil Terbuka																			
		3.610	Landasan/Perletakan	4.611	Landasan																			
				4.612	Peredam Pasif/Damping Struktur																			
				4.613	Peredam Aktif Struktur																			
				4.614	Pendukung landasan																			
				4.615	Penahan pergerakan landasan																			
				4.616	Ikatan / Perletakan Lainnya																			
		3.620	Pengaman Pengguna Jalan	4.621	Struktur Sandaran Railing	301	Penurunan mutu atau kinerja proteksi korosi (lapisan pelindung / cat)					1	1	0	0	0	2	1	1	0	0	0	2	
				4.622	Struktur tembok																			
				4.623	Pembatas lainnya																			

LEVEL 3		Nilai Kondisi				
Kode	Elemen	S	R	K	F	NK
2.800	Gorong-gorong					-
2.900	Struktur Lintasan Basah					-

LEVEL 1		Nilai Kondisi				
Kode	Elemen	S	R	K	F	NK
1.000	Jembatan	1	1	1	0	3



Elemen		Elemen		Elemen		Kerusakan		Lokasi		Level 5					Level 4									
Kode	Uraian Level 2 (pilihan)	Kode	Uraian Level 3 (pilihan)	Kode	Uraian (pilihan)	Kode	Uraian (pilihan)	Nilai Kondisi																
								A/P/B	X	Y	Z	S	R	K	F	P	NK	S	R	K	F	P	NK	
		3.930	Lintasan dengan struktur semi - permanen																					

LEVEL 3		Nilai Kondisi					
Kode	Elemen	S	R	K	F	P	NK



**PEMERINTAH KOTA SEMARANG**  
**DINAS PEKERJAAN UMUM**

JL. MADUKORO RAYA NO. 7, TELP. (024) 76433969, FAX. (024) 76433969 KOTA SEMARANG

NO. JEMBATAN :

KT	3	3	0	7	4	0	2	0	0	2	3	0	0	1	
----	---	---	---	---	---	---	---	---	---	---	---	---	---	---	--

NAMA JEMBATAN :

KEBONHARJO

**POTONGAN MEMANJANG**

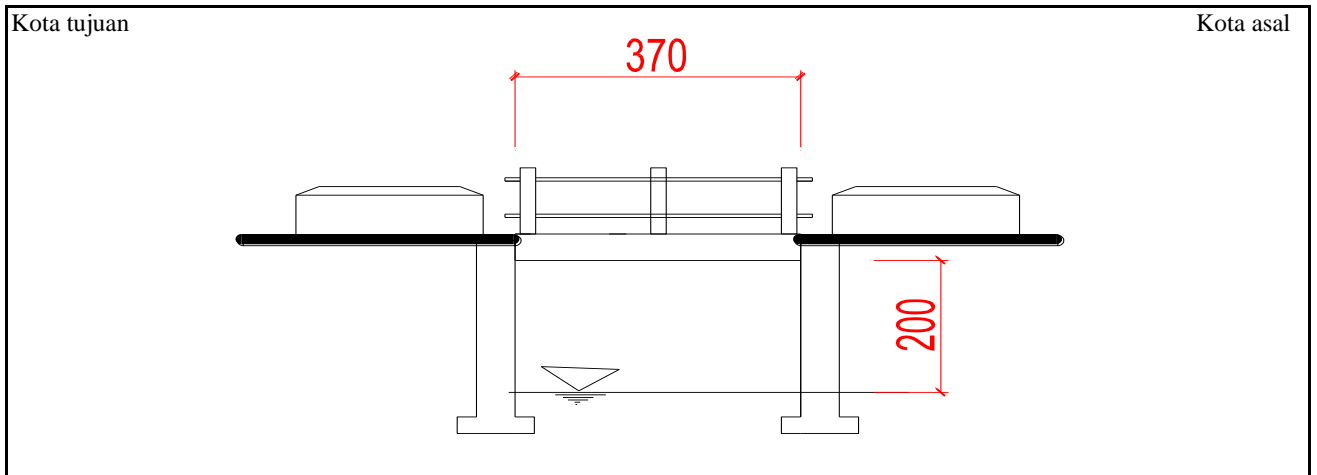

**TAMPAK ATAS**

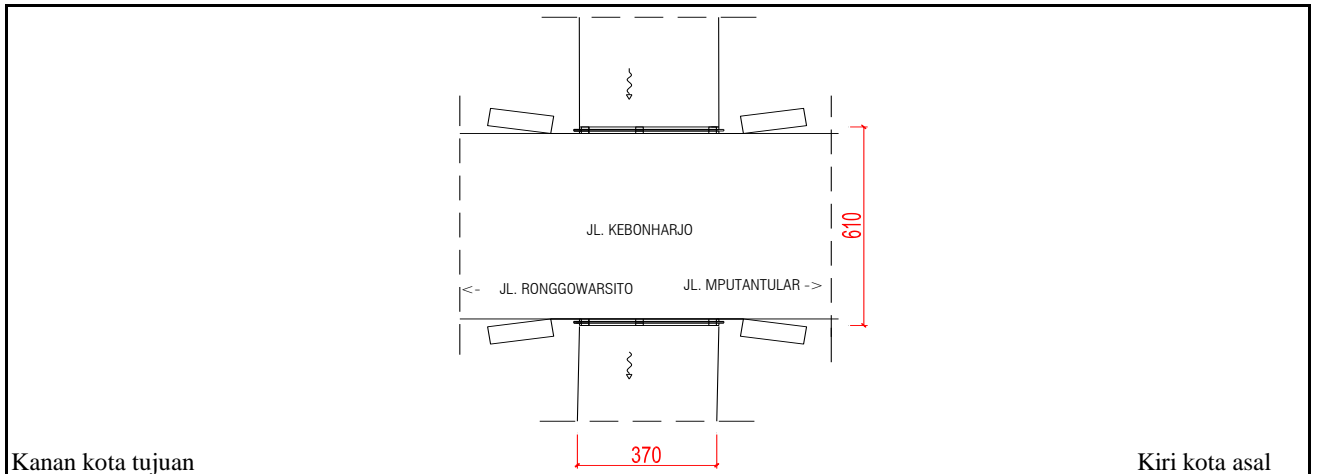

**SITUASI**







**PEMERINTAH KOTA SEMARANG  
DINAS PEKERJAAN UMUM**

JL. MADUKORO RAYA NO. 7, TELP. (024) 76433969, FAX. (024) 76433969 KOTA SEMARANG



**TAMPAK MEMANJANG**



**TAMPAK MEMANJANG**



**TAMPAK MELINTANG**



**TAMPAK MELINTANG**

<b>NOMOR JEMBATAN</b>	<b>NAMA JEMBATAN</b>	<b>LOKASI (Km)</b>	<b>PANJANG (M)</b>
KT.33.074.02.0023.001	KEBONHARJO	1+060	3,70



**PEMERINTAH KOTA SEMARANG  
DINAS PEKERJAAN UMUM**

JL. MADUKORO RAYA NO. 7, TELP. (024) 76433969, FAX. (024) 76433969 KOTA SEMARANG



**TEMBOK SEDADA RUNTUH**



**PENDANGKALAN PADA ALIRAN SUNGAI**



**KEPALA JEMBATAN MENGALAMI  
KERONTOKAN ELEMEN**



**PELAT JEMBATAN KEROPOS**

<b>NOMOR JEMBATAN</b>	<b>NAMA JEMBATAN</b>	<b>LOKASI (Km)</b>	<b>PANJANG (M)</b>
KT.33.074.02.0023.001	KEBONHARJO	1+060	3,70